APPENDIX D

PERMIT APPLICATIONS

Wetlands

Fish Habitat

Material Site Reclamation Plan

Temporary Water Use

Wetlands

U.S. ARMY CORPS OF ENGINEERS
APPLICATION FOR DEPARTMENT OF THE ARMY PERMIT
 33 CFR 325. The proponent agency is CECW-CO-R.

OMB APPROVAL NO. 0710-0003
 EXPIRES: 28 FEBRUARY 2013

Public reporting for this collection of information is estimated to average 11 hours per response, including the time for reviewing instructions, searching existing data sources, gathering and maintaining the data needed, and completing and reviewing the collection of information. Send comments regarding this burden estimate or any other aspect of the collection of information, including suggestions for reducing this burden, to Department of Defense, Washington Headquarters, Executive Services and Communications Directorate, Information Management Division and to the Office of Management and Budget, Paperwork Reduction Project (0710-0003). Respondents should be aware that notwithstanding any other provision of law, no person shall be subject to any penalty for failing to comply with a collection of information if it does not display a currently valid OMB control number. Please DO NOT RETURN your form to either of those addresses. Completed applications must be submitted to the District Engineer having jurisdiction over the location of the proposed activity.

PRIVACY ACT STATEMENT

Authorities: Rivers and Harbors Act, Section 10, 33 USC 403; Clean Water Act, Section 404, 33 USC 1344; Marine Protection, Research, and Sanctuaries Act, Section 103, 33 USC 1413; Regulatory Programs of the Corps of Engineers; Final Rule 33 CFR 320-332. Principal Purpose: Information provided on this form will be used in evaluating the application for a permit. Routine Uses: This information may be shared with the Department of Justice and other federal, state, and local government agencies, and the public and may be made available as part of a public notice as required by Federal law. Submission of requested information is voluntary, however, if information is not provided the permit application cannot be evaluated nor can a permit be issued. One set of original drawings or good reproducible copies which show the location and character of the proposed activity must be attached to this application (see sample drawings and/or instructions) and be submitted to the District Engineer having jurisdiction over the location of the proposed activity. An application that is not completed in full will be returned.

(ITEMS 1 THRU 4 TO BE FILLED BY THE CORPS)

1. APPLICATION NO.	2. FIELD OFFICE CODE	3. DATE RECEIVED	4. DATE APPLICATION COMPLETE
--------------------	----------------------	------------------	------------------------------

(ITEMS BELOW TO BE FILLED BY APPLICANT)

5. APPLICANT'S NAME First - Taralyn Middle - R Last - Stone Company - Alaska Department of Transportation & Public Facilities E-mail Address - taralyn.stone@alaska.gov	8. AUTHORIZED AGENT'S NAME AND TITLE (agent is not required) First - Middle - Last - Company - E-mail Address -
6. APPLICANT'S ADDRESS: Address- PO Box 196900 MS-2525 City - Anchorage State - AK Zip - 99519 Country - USA	9. AGENT'S ADDRESS: Address- City - State - Zip - Country -
7. APPLICANT'S PHONE NOS. w/AREA CODE a. Residence b. Business c. Fax 907-269-0534	10. AGENTS PHONE NOS. w/AREA CODE a. Residence b. Business c. Fax

STATEMENT OF AUTHORIZATION

11. I hereby authorize, _____ to act in my behalf as my agent in the processing of this application and to furnish, upon request, supplemental information in support of this permit application.

 SIGNATURE OF APPLICANT DATE

NAME, LOCATION, AND DESCRIPTION OF PROJECT OR ACTIVITY

12. PROJECT NAME OR TITLE (see instructions) Kwigillingok Airport Improvements	
13. NAME OF WATERBODY, IF KNOWN (if applicable) Unnamed tributary to the Kwigillingok River	14. PROJECT STREET ADDRESS (if applicable) Address N/A
15. LOCATION OF PROJECT Latitude: +N 59.875879 Longitude: +W 163.167675	City - Kwigillingok State- AK Zip- 99622
16. OTHER LOCATION DESCRIPTIONS, IF KNOWN (see instructions) State Tax Parcel ID Municipality Kwigillingok Section - 35 Township - 03 South Range - 81 West	

17. DIRECTIONS TO THE SITE

Fly to Bethel, regularly scheduled or charter flights to Kwigillingok are available. The Kwigillingok Airport is located immediately west of the Village of Kwigillingok.

18. Nature of Activity (Description of project, include all features)

The project includes constructing a 3,780 foot long by 120 foot wide lighted runway and safety area with a taxiway, apron, pads for navigational aids, 2 Snow Removal Equipment Buildings (one heated, one unheated), an access road, and a hauling road and staging area to import barged surface course (gravel) material for construction. Two areas near the airport are expected to be used (dredged/excavated) by the contractor to obtain unclassified embankment material. See Attachment for further details.

19. Project Purpose (Describe the reason or purpose of the project, see instructions)

The purpose of the proposed project is to improve reliability and safety for air travel to Kwigillingok. To achieve this, airport deficiencies will be corrected to bring the airport up to current State and FAA design standards. See Attachment for further details.

USE BLOCKS 20-23 IF DREDGED AND/OR FILL MATERIAL IS TO BE DISCHARGED

20. Reason(s) for Discharge

Placement of material is required to enlarge the airport landing and parking areas and access roads to the airport. The entire airport property and region consists of or is surrounded by Palustrine, Riverine, and open water wetlands. Avoidance is not possible. See Attachment for further details.

21. Type(s) of Material Being Discharged and the Amount of Each Type in Cubic Yards:

Type Amount in Cubic Yards	Type Amount in Cubic Yards	Type Amount in Cubic Yards
27,400 cy Surface Course	519,600 cy embankment	547,000 cy

22. Surface Area in Acres of Wetlands or Other Waters Filled (see instructions)

Acres 128 acres
or
Linear Feet

23. Description of Avoidance, Minimization, and Compensation (see instructions)

See Attachment.

24. Is Any Portion of the Work Already Complete? Yes No IF YES, DESCRIBE THE COMPLETED WORK

25. Addresses of Adjoining Property Owners, Lessees, Etc., Whose Property Adjoins the Waterbody (if more than can be entered here, please attach a supplemental list).

a. Address- Lena Atti (Native Allotment) Lot 4, U.S. Survey 10435, located in Bethel Recording District

City - Kwigillingok State - Alaska Zip - 99545

b. Address- Native Village of Kwigillingok P.O. Box 49

City - Kwigillingok State - Alaska Zip - 99622

c. Address- Heirs of Eva Friend (Native Allotment) Lots 2 & 8, U.S. Survey 10435, located in the Bethel Recording District

City - Kwigillingok State - Alaska Zip - 99545

d. Address- Calista Corporation 301 Calista Court, Suite A

City - Anchorage State - Alaska Zip - 99518

e. Address- State of Alaska Department of Natural Resources - 550 W. 7th Avenue

City - Anchorage State - Alaska Zip - 99501

26. List of Other Certificates or Approvals/Denials received from other Federal, State, or Local Agencies for Work Described in This Application.

AGENCY	TYPE APPROVAL*	IDENTIFICATION NUMBER	DATE APPLIED	DATE APPROVED	DATE DENIED
SHPO Section 106	Finding of No Affect		Sept. 5, 2013	Sept. 19, 2013	
ADEC	401 Certification		Concurrent		
ADNR	TWUP		Concurrent		
ADFG	Fish Habitat Permit		Concurrent		

* Would include but is not restricted to zoning, building, and flood plain permits

27. Application is hereby made for permit or permits to authorize the work described in this application. I certify that this information in this application is complete and accurate. I further certify that I possess the authority to undertake the work described herein or am acting as the duly authorized agent of the applicant.

SIGNATURE OF APPLICANT

DATE

SIGNATURE OF AGENT

DATE

The Application must be signed by the person who desires to undertake the proposed activity (applicant) or it may be signed by a duly authorized agent if the statement in block 11 has been filled out and signed.

18 U.S.C. Section 1001 provides that: Whoever, in any manner within the jurisdiction of any department or agency of the United States knowingly and willfully falsifies, conceals, or covers up any trick, scheme, or disguises a material fact or makes any false, fictitious or fraudulent statements or representations or makes or uses any false writing or document knowing same to contain any false, fictitious or fraudulent statements or entry, shall be fined not more than \$10,000 or imprisoned not more than five years or both.

USACE Section 404 Individual Permit Application: Supplemental Information

1 PROJECT INFORMATION

The proposed action is to improve the existing airport to meet ADOT&PF and FAA standards for a Community Class airport. Due to the short-term safety needs, geotechnical considerations and funding constraints, construction for the project is anticipated to be staged. Stage I, proposed for construction starting in 2016 or 2017, depending on funding, would include placing silt embankment materials and raising the grade of the existing runway. The new embankments would be allowed to consolidate and settle. Stage II would place additional material on the new embankments and complete the proposed airport improvements.

Stage I would begin with summer mobilization of equipment by barge to Kwigillingok. The following winter material would be excavated and hauled to the airport. Embankment material would be placed on the new access road, apron, taxiway, and to widen and extend the runway. An ice road would be constructed to facilitate access to the work site for the channel realignment. The tidal channel would be realigned by excavating a new channel and the old channel filled in with the excavated material (Figure 2). The following summer (2017 or 2018), the existing runway surfacing would be completed.

The timing of Stage II would be determined by the success of the first stage and runway compaction rates, funding, and updating of the environmental documentation. This stage would barge in and place additional gravel and surfacing material on the runway, taxiway, apron and access road embankments. It would also include construction of the new Snow Equipment Removal Buildings (SREBs), airport lighting and navigational aids. This stage is anticipated to begin around 2021 (depending on funding and settlement rates).

For both stages, and for the permit coverage, the improvements would include the following components (Figures 1-8):

- Expand the existing runway to 3,300 feet long by 60 feet wide. The total runway and safety area dimensions would be 3,780 feet by 120 feet (typical section on Figures 2 and 3).
- Expand the taxiway to the apron to 35 feet wide (typical section on Figure 4). The total width of the taxiway safety area would be 79 feet (Airplane Design Group II, Taxiway Design Group 2; the larger safety area allows for snow removal and occasional operations by larger aircraft).
- Construct a new, 374-foot by 300-foot apron and aviation support area (typical section on Figure 5).
- Build two SREBs on the aviation support area (one heated and one for cold storage).
- Improve runway and taxiway lighting to include Medium Intensity Runway and Taxiway Lighting (MIRL), a pad for the Runway End Identifier Lights (REIL), a pad for the Automated Weather Observing System (AWOS), two pads for Precision Approach Path Indicator (PAPI) lights, and a segmented circle.
- Install wind cones, a segmented circle, and a rotating beacon to aid navigation.
- Build a 24-foot-wide access road between the apron and the main road connecting to the community.

- Acquire approximately 285 acres for the runway improvements, future crosswind runway, and access road.
- Install an overhead power line to power the new SREBs.
- Relocate the portion of the Kinak-Kipnuk trail that runs through the proposed runway extension.

See Figure 2 for further details of the proposed action.

In order to construct the proposed action, the contractor would need to develop two material sites (Material Sites A and B; Figure 6) and establish a connecting access road from the runway area to the material sites prior to construction. A haul route from the Kwigillingok River to the airport is needed; this can be provided by improving an existing public easement trail (typical section illustrated on Figure 7). Additionally, the contractor would need a staging area for imported gravel and surface course material. Timing on these methods is dependent on the contractor means and methods.

2 SECTION 404

Approximately 128 acres of wetlands would be affected by the project (Figure 2 and Table 1).

Table 1: Wetlands Impacts – Proposed Action

	Project Component	Wetland Type	Area of Wetland Impact (ac)	Total Fill (cy)
Fill and Temporary Impact (Buffer)	Primary Runway <i>Including PAPI Pads</i>	OW	4.1	31,500
		PEM	21.2	166,900
		R	2.4	19,500
	Taxiway	OW	0.1	300
		PEM	1.6	10,200
	Apron <i>Including Segmented Circle</i>	OW	0.1	1,100
		PEM	6.1	50,600
	Haul Route	OW	0.9	3,300
		PEM	8.2	27,600
		R	0.1	300
Access Road	OW	0.2	1,100	
	PEM	1.6	4,600	
	Staging	PEM	7.2	52,000
OW/PEM to OW/PEM Conversion	Material Sources A & B <i>Excavation Impacts and Temporary Overburden Stockpile</i>	PEM	56.8	97,000
PEM/R to OW/PEM/R Conversion	Fill Channel	PEM	4.0	40,000
		R	4.1	41,000
	New Channel	OW	1.3	0
		PEM	7.6	0
		R	0.6	0
	TOTALS		128	547,000

OW = Open Water; PEM = Palustrine Emergent Wetlands; R = Riverine

Note: A uniform 20-foot buffer around the entire perimeter of impacted areas was included in the calculations to account for temporary impacts as a result of equipment maneuvering and sedimentation at the embankment toe.

Table 2 – Total Impacted Area by Wetland Type

PEM Palustrine Emergent Wetlands	114.2 ac
OW Open Water	6.7 ac
R Riverine	7.2 ac
Total Impact (rounded)	128.0 ac

3 AVOIDANCE OF IMPACTS

The project is being developed in accordance with the USACE Alaska District RGL 09-01. An ADEC Section 401 Water Quality Certification will be obtained. All stipulations and special conditions of the permits will be followed. Wetland fill has been avoided to the maximum extent.

Avoidance measures that have been incorporated in the project include:

- Expansion of the existing airport embankments as opposed to disturbing an entirely new location (for airport re-location) or rotation of the runway off the existing footprint.
- Use of an existing ATV trail for the proposed haul route.

4 MINIMIZATION OF UNAVOIDABLE IMPACTS

Minimization measures that have been incorporated in the project include:

- Siting the apron in an area requiring the least embankment fill.
- The potential for sediment transport off the project site would be minimized by the use of a 20-foot vegetated buffer around the airport footprint, and implementing BMPs that will be identified in the SWPPP.
- Side slopes would be revegetated immediately after the embankment is placed.
- The majority of construction is anticipated to be scheduled during winter months, minimizing the effect on wetlands.
- Planning the shortest route possible to the airport from the community.

Due to the quality of local embankment material, constructing fill slopes steeper than normal is problematic. Previous DOT&PF experience has shown that using steeper side slopes with the type of material available in Kwigillingok and on soils similar to those in Kwigillingok would likely result in sloughing material, slope erosion, and embankment failure(s).

5 COMPENSATION

Compensatory mitigation for unavoidable impacts to 128 acres of wetlands shall be provided in accordance with USACE RGL ID No. 09-01, which requires a mitigation plan based on the functions and values of the affected wetlands, and compensatory mitigation for federally funded projects.

DOT&PF proposes in-lieu fee compensatory mitigation at a 2:1 ratio. As a result, the compensatory mitigation for this project must be sufficient to purchase and permanently preserve 256 acres of similar wetlands. Based on the 2013 AKILF Program Instrument's proposed fees, Southwest remote slope/flat/depressional wetlands have a mitigation rate of \$5,500 a credit. For Kwigillingok, a base mitigation rate of \$5,500 per acre was used to estimate the mitigation fee. The total in-lieu compensatory mitigation fee for this project would be \$1,408,000.

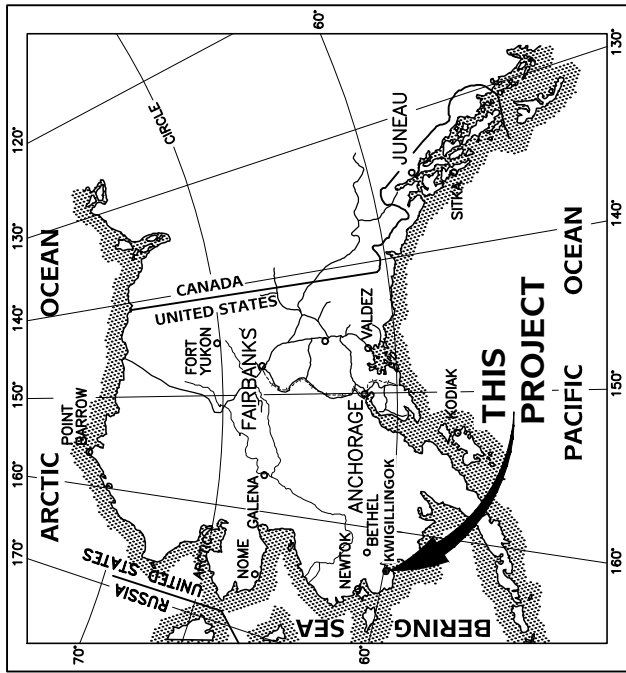

LOCATION MAP

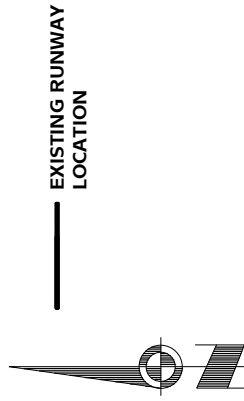

**SEC 26, 27, 34, 35, T3S, R81W;
SEWARD MERIDIAN**

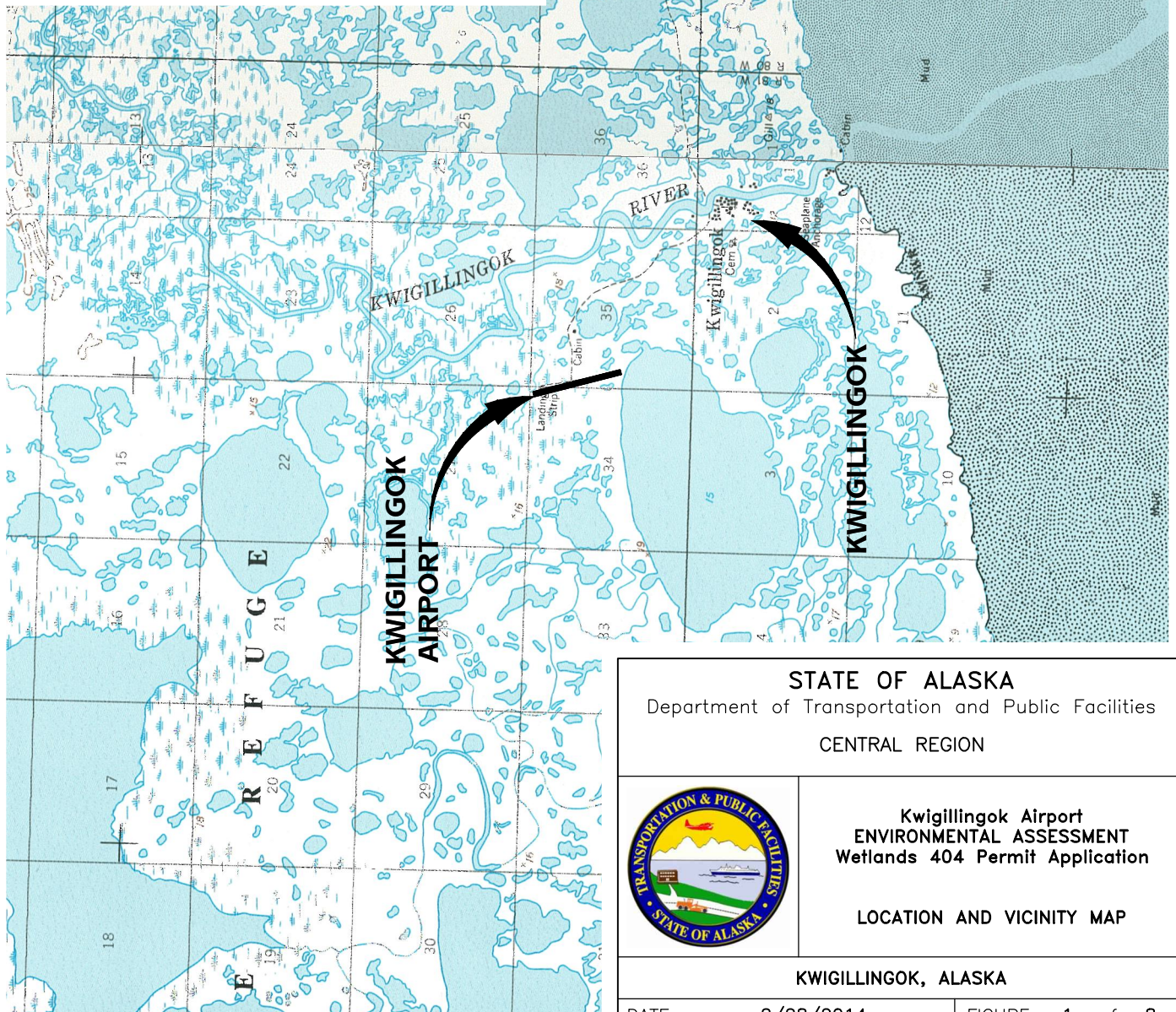
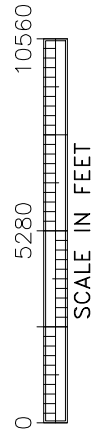

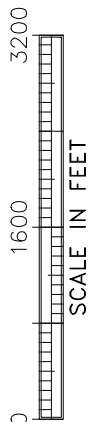

<p>STATE OF ALASKA Department of Transportation and Public Facilities CENTRAL REGION</p>	
	<p>Kwigillingok Airport ENVIRONMENTAL ASSESSMENT Wetlands 404 Permit Application</p> <p>LOCATION AND VICINITY MAP</p>
<p>KWIGILLINGOK, ALASKA</p>	
DATE:	2/28/2014
FIGURE:	1 of 8

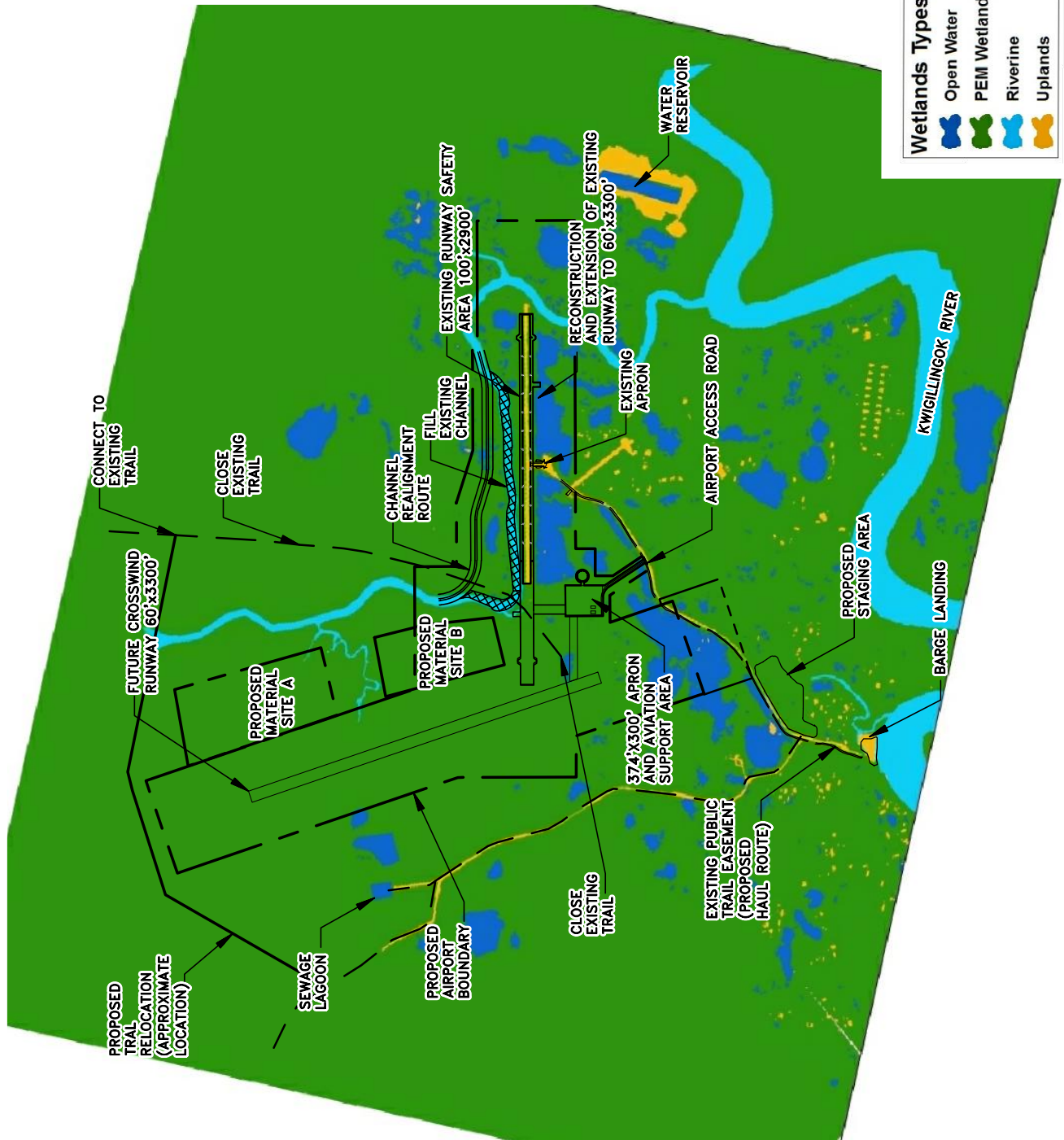

NOTES:

1. THE 2013 WETLANDS DELINEATION WAS DEVELOPED USING ETERRA PHOTOGRAPHY, SITE PHOTOGRAPHS, AND THE MOST CURRENT AVAILABLE NWI MAPS PROVIDED BY THE U.S. FISH AND WILDLIFE SERVICE.



<p>STATE OF ALASKA Department of Transportation and Public Facilities CENTRAL REGION</p>	
	<p>Kwigillingok Airport ENVIRONMENTAL ASSESSMENT Wetlands 404 Permit Application</p> <p>WETLANDS AND PROPOSED ACTION</p>
<p>KWIGILLINGOK, ALASKA</p>	
DATE:	2/28/2014
FIGURE:	2 of 8

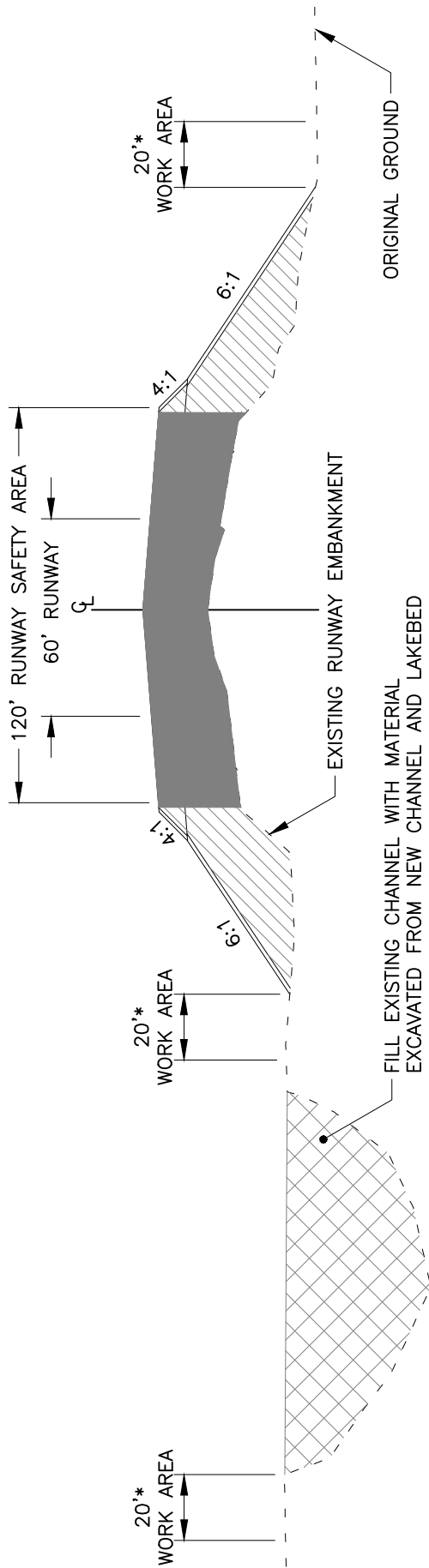

EXISTING RUNWAY RECONSTRUCTION TYPICAL SECTION

- FILL IN CHANNEL
- FILL IN WETLANDS
- FILL IN UPLANDS

* WORK AREA 20' BEYOND FILL LIMITS IS FOR A VEGETATIVE BUFFER TO PROVIDE EROSION CONTROL.

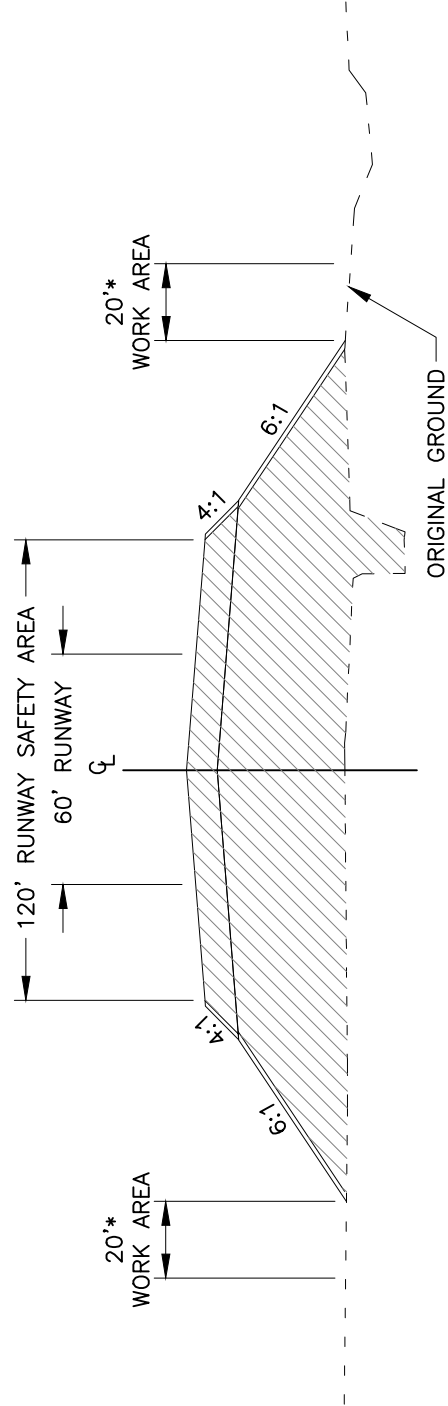

RUNWAY EXTENSION TYPICAL SECTION

- FILL IN WETLANDS

<p>STATE OF ALASKA Department of Transportation and Public Facilities CENTRAL REGION</p>	
	<p>Kwigillingok Airport ENVIRONMENTAL ASSESSMENT Wetlands 404 Permit Application</p> <p>TYPICAL SECTION TYPICAL SECTION OF RUNWAY</p>
<p>KWIGILLINGOK, ALASKA</p>	
<p>DATE: 2/28/2014</p>	<p>FIGURE: 3 of 8</p>

P:\2010\F10101\N\N1001\uceF10101: Typical Section of Taxiway Fri, 28/Feb/14 10:06 AM

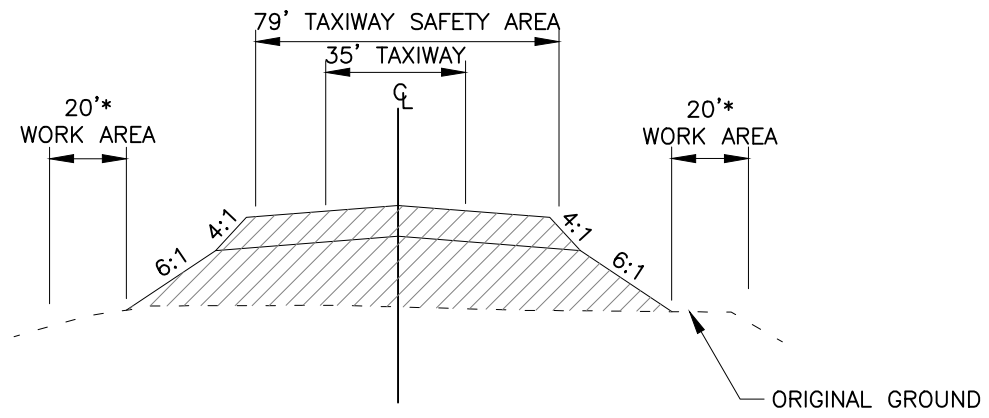

TAXIWAY TYPICAL SECTION

 FILL IN WETLANDS

* WORK AREA 20' BEYOND FILL LIMITS IS FOR A VEGETATIVE BUFFER TO PROVIDE EROSION CONTROL.

STATE OF ALASKA Department of Transportation and Public Facilities CENTRAL REGION	
	Kwigillingok Airport ENVIRONMENTAL ASSESSMENT Wetlands 404 Permit Application TYPICAL SECTION TYPICAL SECTION OF TAXIWAY
KWIGILLINGOK, ALASKA	
DATE:	2/28/2014
	FIGURE: 4 of 8

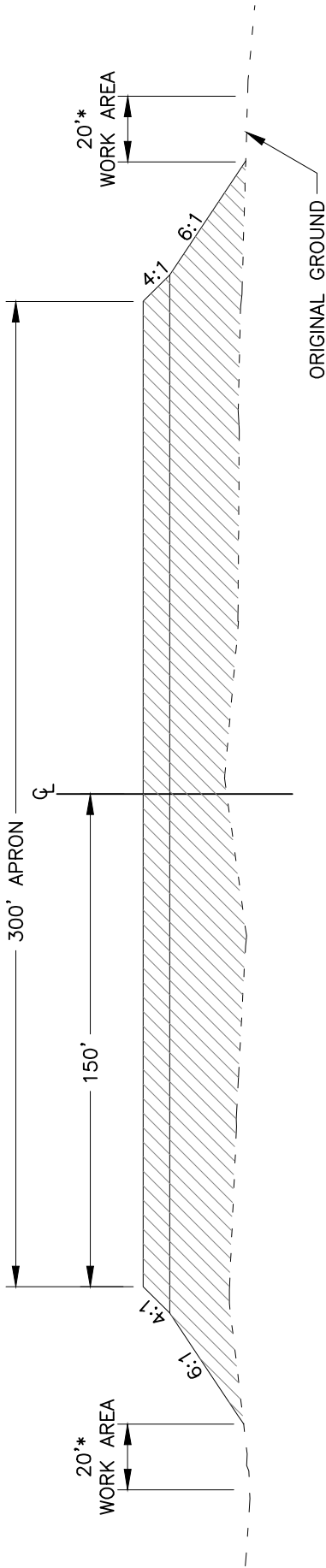

APRON TYPICAL SECTION

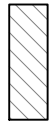
 FILL IN WETLANDS

* WORK AREA 20' BEYOND FILL LIMITS IS FOR A VEGETATIVE BUFFER TO PROVIDE EROSION CONTROL.

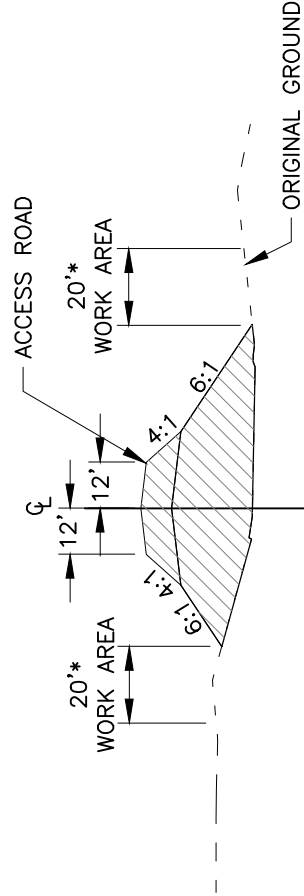

AIRPORT ACCESS ROAD TYPICAL SECTION

 FILL IN WETLANDS

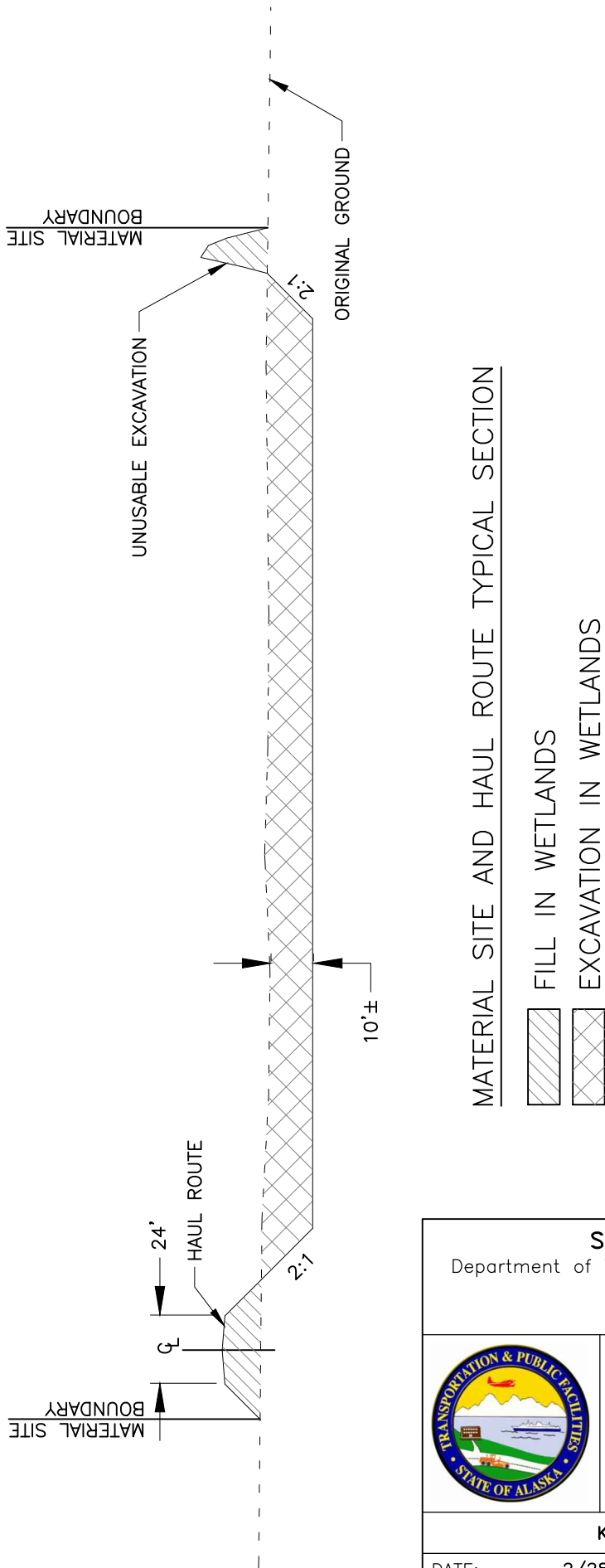

<p>STATE OF ALASKA Department of Transportation and Public Facilities CENTRAL REGION</p>	
	<p>Kwigillingok Airport ENVIRONMENTAL ASSESSMENT Wetlands 404 Permit Application</p> <p>TYPICAL SECTION TYPICAL SECTION OF APRON AND ACCESS ROAD</p>
<p>KWIGILLINGOK, ALASKA</p>	
DATE:	2/28/2014
FIGURE:	5 of 8

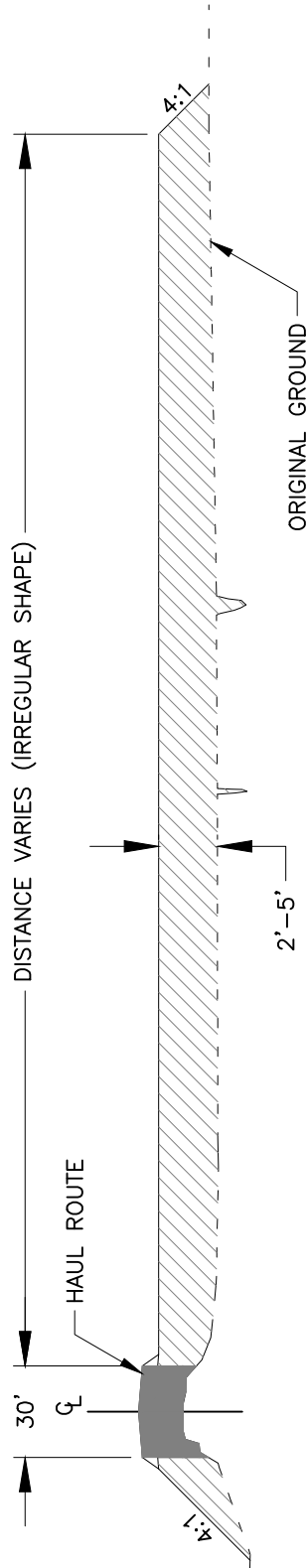

<p>STATE OF ALASKA Department of Transportation and Public Facilities CENTRAL REGION</p>	
	<p>Kwigillingok Airport ENVIRONMENTAL ASSESSMENT Wetlands 404 Permit Application</p> <p>TYPICAL SECTION MATERIAL SITES A AND B</p>
<p>KWIGILLINGOK, ALASKA</p>	
DATE:	2/28/2014
FIGURE:	6 of 8



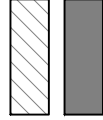

HAUL ROUTE AND STAGING AREA TYPICAL SECTION

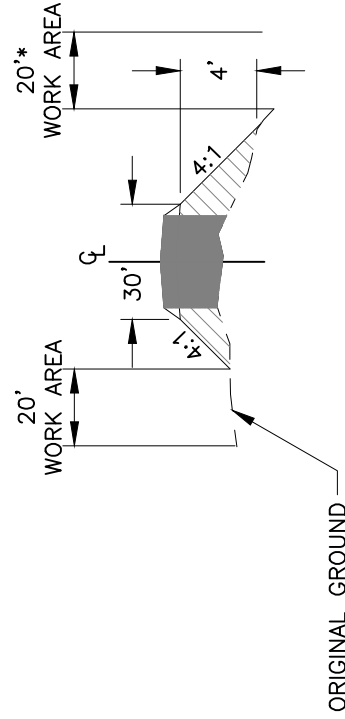
-  FILL IN WETLANDS
-  FILL IN UPLANDS

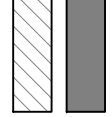

HAUL ROUTE TYPICAL SECTION

-  FILL IN WETLANDS
-  FILL IN UPLANDS

* WORK AREA 20' BEYOND FILL LIMITS IS FOR A VEGETATIVE BUFFER TO PROVIDE EROSION CONTROL

<p>STATE OF ALASKA Department of Transportation and Public Facilities CENTRAL REGION</p>	
	<p>Kwigillingok Airport ENVIRONMENTAL ASSESSMENT Wetlands 404 Permit Application</p> <p>TYPICAL SECTION MATERIAL HAUL ROUTE TYPICAL SECTION</p>
<p>KWIGILLINGOK, ALASKA</p>	
DATE:	2/28/2014
FIGURE:	7 of 8

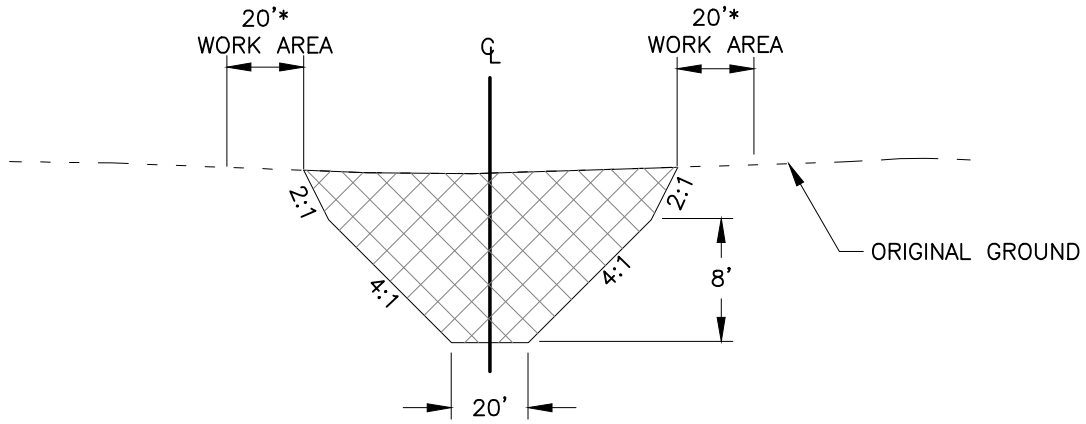

CHANNEL TYPICAL SECTION

 EXCAVATION

* WORK AREA 20' BEYOND EXCAVATION LIMIT IS FOR A VEGETATIVE BUFFER TO PROVIDE EROSION CONTROL

<p>STATE OF ALASKA Department of Transportation and Public Facilities CENTRAL REGION</p>	
	<p>Kwigillingok Airport ENVIRONMENTAL ASSESSMENT Wetlands 404 Permit Application</p> <p>TYPICAL SECTION TYPICAL SECTION OF CHANNEL RE-ROUTE</p>
<p>KWIGILLINGOK, ALASKA</p>	
DATE:	2/28/2014
FIGURE: 8	of 8

Fish Habitat



ALASKA DEPARTMENT OF FISH AND GAME FISH HABITAT PERMIT APPLICATION SPECIFIC INSTRUCTIONS

- NOTE:** Provide as much information as possible. If you need assistance, please contact the nearest ADF&G Division of Habitat office. The ADF&G reserves the right to require additional information for the proper protection of fish and game.
- Step A:** Provide your name, address, and telephone number and the name, address, and telephone number of the contractor who will be doing the work, if known.
- Step B:** Describe the type of project (e.g., bridge, culvert, utility line placement, impoundment structure, bank stabilization, channelization, low water crossing, log removal, etc.) and the purpose of the project. A brief description of alternatives considered would be useful but is not required. Attach additional sheets as necessary. [Back to Form](#)
- Step C:**
1. Name of the waterbody in or adjacent to which the project will occur.
 2. For Anadromous Stream numbers, refer to the [Atlas to the Catalog of Waters Important for Spawning, Rearing or Migration of Anadromous Fishes](#).
 3. a. Provide plans (or field sketch) showing the following as a minimum: access to the site, plan view showing all project features and dimensions, or crossing/fording sites; material removal plans should also include, at a minimum, the following: 50' contour lines; nearby watercourses and lakes; location of facilities (i.e., screening, washing, and crushing plants, and commercial and private buildings); aliquot parts identified in order they are to be mined; site where fuel will be stored; a cross section view of the material site showing current land and water elevations and bank slopes and final excavation grades and slopes; and project expansion sites (scale no greater than 1 in. = 400 ft.)
 - b. Provide specifications, if available; and
 - c. Provide a current aerial photograph, if available. [Back to Form](#)
- Step D:** Indicate the time of year when project construction will occur. Is the project temporary or permanent?
- Step E:**
1. Provide information if applicable on how you will divert the stream.
 2. Indicate if channelization will occur.
 3. Provide information, if applicable, on how you will alter or modify the banks of the stream.
 4. List all vehicles or equipment by type and size that will be used in the stream.
 5. Provide information, if applicable, on what type and amount of material will be removed from the floodplain, bed, stream, or lake.
 6. Provide information, if applicable, on any material you will deposit in the floodplain, stream, or lake.

7. Provide information, if applicable, on any blasting you intend to do in the floodplain, stream, or lake.
8. Indicate if temporary fills will be required.
9. Indicate if ice bridges will be required.

Step F: What precautions will be taken to insure that fish and other aquatic organisms are protected from adverse impacts? Outline plan for restoring, rehabilitating, or re-vegetating the site if channel or bank alterations occur. What precautions will be taken to maintain State Water Quality Standards? [Back to Form](#)

Step G: Provide the waterbody characteristics at the site of the project.

Step H: Provide available hydraulic information for the types of projects indicated. For information on selecting a culvert size that will ensure fish passage, consult ADF&G permittees or references available at Division of Habitat offices.



FH# _____
(Office Use Only)

GENERAL WATERWAY/WATERBODY APPLICATION
ALASKA DEPARTMENT OF FISH AND GAME
Division of Habitat
Office Locations

A. APPLICANT

1. Name: Alaska Department of Transportation & Public Facilities
2. Address (Mailing): PO BOX 196900, Anchorage, AK 99519
 Email Address: taralyn.stone@alaska.gov
 Telephone: (907) 269-0534 Fax: _____
3. Project Coordinator/Contractor:
 Name: Taralyn Stone, Environmental Team Leader
 Address: DOT&PF
 Email Address: taralyn.stone@alaska.gov
 Telephone: (907)269-0534 Fax: _____

B. TYPE AND PURPOSE OF PROJECT: _____

ICE ROAD CONSTRUCTION/KWIGILLINGOK RIVER DEWATERING

The proposed project consists of airport improvements to the existing Kwigillingok Airport to bring deficiencies up to current State and FAA standards. Project components include: constructing a 3,780 foot long by 120 foot wide lighted runway and safety area with a taxiway, apron, navigational aids, 2 Snow Removal Equipment Buildings (one heated, one unheated) and an access road. Supplemental work includes: providing a haul road and staging area to import barged material for construction; and realignment of a channel currently eroding the embankment of the existing runway.

The purpose of the proposed project is to improve safety at the airport. This application covers dewatering activities for the winter construction of ice roads. It is the intent to be able to use both the Kwigillingok River main stream and its tributaries.

C. LOCATION OF PROJECT SITE

1. Name of River, Stream, or Lake: Kwigillingok River,
 or Anadromous Stream No: Kwigillingok River = Stream No. 335-40-15950
2. Legal Description: Township 03S Range 81 W
 Meridian SM Section 35 USGS Quad Map _____
3. Plans, Specifications, and Aerial Photograph. See specific instructions

D. **TIME FRAME FOR PROJECT:** Winter 2015 TO Winter 2017 (mm/dd/yy)

E. **CONSTRUCTION METHODS:**

1. Will the stream be diverted? Yes No
How will the stream be diverted? n/a
How long? n/a
2. Will stream channelization occur? Yes No
3. Will the banks of the stream be altered or modified? Yes No
Describe: n/a
4. List all tracked or wheeled equipment (type and size) that will be used in the stream (in the water, on ice, or in the floodplain): Water truck with intake line (on ice)
How long will equipment be in the stream? Only during construction, only during pumping.
5. a. Will material be removed from the floodplain, bed, stream, or lake? Yes No
Type: n/a
Amount: n/a
b. Will material be removed from below the water table? Yes No
If so, to what depth? n/a
Is a pumping operation planned? Yes No
6. Will material (including spoils, debris, or overburden) be deposited in the floodplain, stream, or lake? Yes No
If so, what type? n/a
Amount: n/a
Disposal site location(s): Only water will be deposited along designated Haul Routes.
7. Will blasting be performed? Yes No
Weight of charges: n/a
Type of substrate: n/a
8. Will temporary fills in the stream or lake be required during construction (e.g., for construction traffic around construction site)? Yes No
9. Will ice bridges be required? Yes No

F. **SITE REHABILITATION/RESTORATION PLAN:** On a separate sheet present a site rehabilitation/restoration plan. [See specific instructions](#)

G. **WATERBODY CHARACTERISTICS:**

Width of stream: 1000' Depth of stream or lake: TBD

Type of stream or lake bottom (e.g., sand, gravel, mud): silt and fine sands

Stream gradient: 0.06 % (0.0006 ft/ft)

H. **HYDRAULIC EVALUATION:**

1. Will a structure (e.g., culvert, bridge support, dike) be placed below ordinary high water of the stream? Yes No

If yes, attach engineering drawings or a field sketch, as described in [Step B](#).

For culverts, attach stream discharge data for a mean annual flood (Q=2.3), if available.

If applicable, describe potential for channel changes and/or increased bank erosion:

2. Will more than 25,000 cubic yards of material be removed? Yes No

If yes, attach a written hydraulic evaluation including, at a minimum, the following: potential for channel changes, assessment of increased aufeis (glaciering) potential, assessment of potential for increased bank erosion.

I HEREBY CERTIFY THAT ALL INFORMATION PROVIDED ON OR IN CONNECTION WITH THIS APPLICATION IS TRUE AND COMPLETE TO THE BEST OF MY KNOWLEDGE AND BELIEF.

Signature of Applicant

Date

**Alaska Department of Fish and Game Division of Habitat
Fish Habitat Permit Application: Attachment**

Kwigillingok Airport Improvements

ICE ROAD CONSTRUCTION

F. SITE REHABILITATION/RESTORATION PLAN

As required by the application instructions (Step F), this plan outlines the precautions taken to insure that fish and other aquatic organisms are protected from adverse impacts. If channel or bank alterations occur, this plan outlines the steps to be taken to restore, rehabilitate, or re-vegetate the site. Finally, this plan also outlines the precautions to be taken to maintain State Water Quality Standards.

In order to ensure that **fish and aquatic organisms are protected from adverse impacts**, the project's work plan will include the following requirements:

1. In order to avoid entrainment or injury to fish, a properly sized and screened structure must surround the water intake. The intake screen will be monitored during operations to ensure the screening is functional and that no blockage by debris has occurred.
2. The streambed and bank of the river will not be excavated or altered in any manner to facilitate the water withdrawal.

If **channel or bank alterations occur**, the following steps will be taken to restore and rehabilitate the site:

- Stream banks will not be altered or disturbed to facilitate the ice road. Should an unexpected activity disturb the bank or channel, work will stop immediately. The ADFG Division of Habitat will be notified and consulted.

In order to **maintain State Water Quality Standards**, the following steps will be taken:

- Winter construction will avoid and minimize sediments from contributing to the turbidity of the channel.

As an added precaution, a copy of the pending permit will be kept on site. Should any unexpected activity arise, and work deviates from this plan, the ADF&G Division of Habitat will be notified. Work will be dependent on the receipt of written approval for the permit amendment before resuming work.

NOTES:

1. PROPOSED AIRPORT BOUNDARY IS THE PROPOSED AIRPORT ACQUISITION AND INCLUDES THE LAND NEEDED FOR THE FUTURE CROSSWIND RUNWAY.
2. CONSTRUCTION OF THE FUTURE CROSSWIND RUNWAY IS NOT PART OF THIS PROJECT.

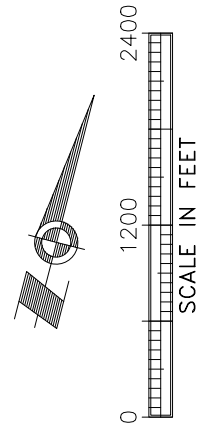
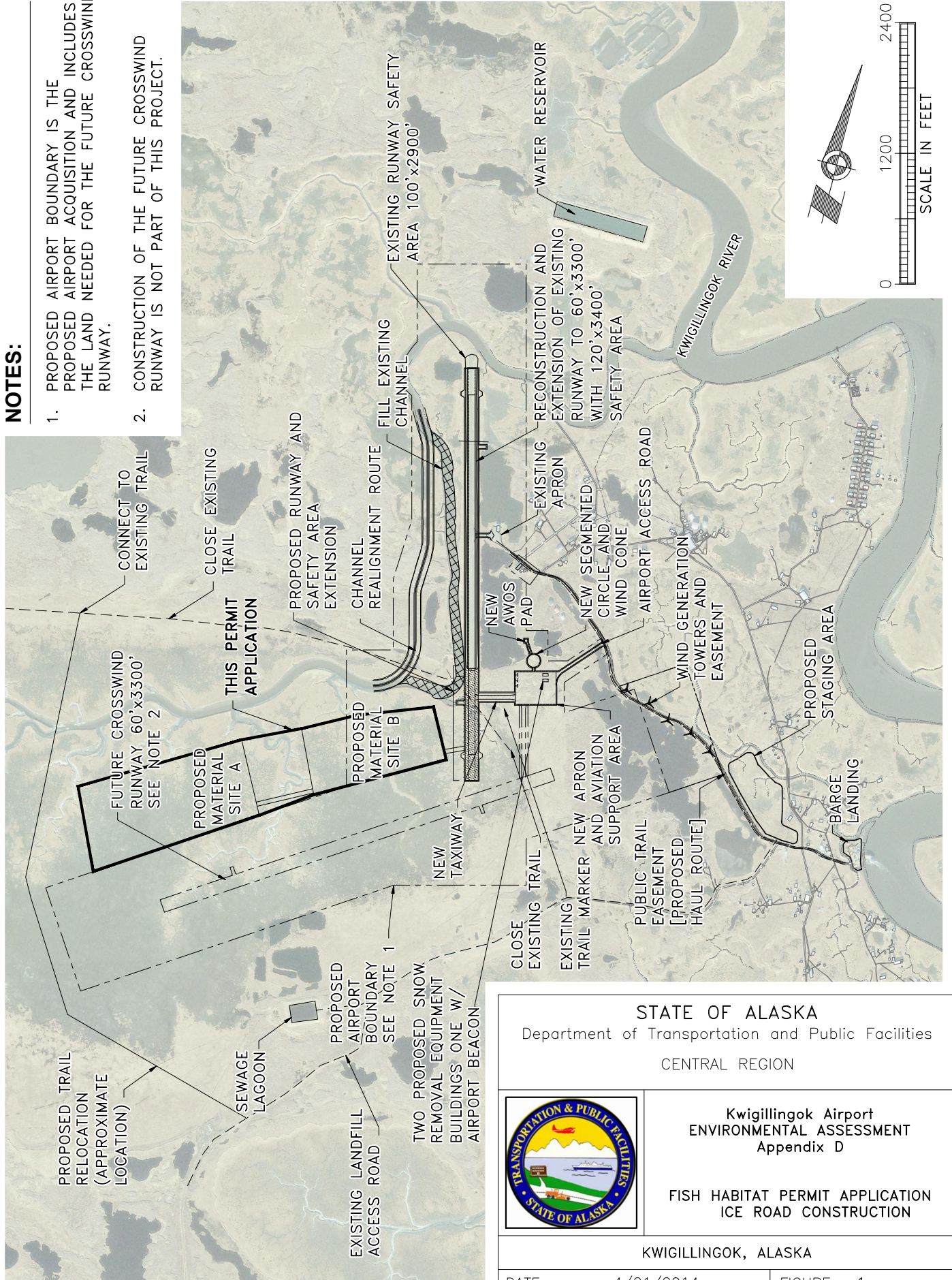

<p>STATE OF ALASKA Department of Transportation and Public Facilities CENTRAL REGION</p>	
	<p>Kwigillingok Airport ENVIRONMENTAL ASSESSMENT Appendix D</p>
<p>FISH HABITAT PERMIT APPLICATION ICE ROAD CONSTRUCTION</p>	
<p>KWIGILLINGOK, ALASKA</p>	
DATE:	4/21/2014
FIGURE:	1



ALASKA DEPARTMENT OF FISH AND GAME FISH HABITAT PERMIT APPLICATION SPECIFIC INSTRUCTIONS

NOTE: Provide as much information as possible. If you need assistance, please contact the nearest ADF&G Division of Habitat office. The ADF&G reserves the right to require additional information for the proper protection of fish and game.

Step A: Provide your name, address, and telephone number and the name, address, and telephone number of the contractor who will be doing the work, if known.

Step B: Describe the type of project (e.g., bridge, culvert, utility line placement, impoundment structure, bank stabilization, channelization, low water crossing, log removal, etc.) and the purpose of the project. A brief description of alternatives considered would be useful but is not required. Attach additional sheets as necessary. [Back to Form](#)

Step C: **1.** Name of the waterbody in or adjacent to which the project will occur.

2. For Anadromous Stream numbers, refer to the [Atlas to the Catalog of Waters Important for Spawning, Rearing or Migration of Anadromous Fishes](#).

3. a. Provide plans (or field sketch) showing the following as a minimum: access to the site, plan view showing all project features and dimensions, or crossing/fording sites; material removal plans should also include, at a minimum, the following: 50' contour lines; nearby watercourses and lakes; location of facilities (i.e., screening, washing, and crushing plants, and commercial and private buildings); aliquot parts identified in order they are to be mined; site where fuel will be stored; a cross section view of the material site showing current land and water elevations and bank slopes and final excavation grades and slopes; and project expansion sites (scale no greater than 1 in. = 400 ft.)

b. Provide specifications, if available; and

c. Provide a current aerial photograph, if available. [Back to Form](#)

Step D: Indicate the time of year when project construction will occur. Is the project temporary or permanent?

Step E: **1.** Provide information if applicable on how you will divert the stream.

2. Indicate if channelization will occur.

3. Provide information, if applicable, on how you will alter or modify the banks of the stream.

4. List all vehicles or equipment by type and size that will be used in the stream.

5. Provide information, if applicable, on what type and amount of material will be removed from the floodplain, bed, stream, or lake.

6. Provide information, if applicable, on any material you will deposit in the floodplain, stream, or lake.

7. Provide information, if applicable, on any blasting you intend to do in the floodplain, stream, or lake.
8. Indicate if temporary fills will be required.
9. Indicate if ice bridges will be required.

Step F: What precautions will be taken to insure that fish and other aquatic organisms are protected from adverse impacts? Outline plan for restoring, rehabilitating, or re-vegetating the site if channel or bank alterations occur. What precautions will be taken to maintain State Water Quality Standards? [Back to Form](#)

Step G: Provide the waterbody characteristics at the site of the project.

Step H: Provide available hydraulic information for the types of projects indicated. For information on selecting a culvert size that will ensure fish passage, consult ADF&G permittees or references available at Division of Habitat offices.



FH# _____
(Office Use Only)

GENERAL WATERWAY/WATERBODY APPLICATION
ALASKA DEPARTMENT OF FISH AND GAME
Division of Habitat
Office Locations

A. APPLICANT

- Name: Alaska Department of Transportation & Public Facilities
- Address (Mailing): PO BOX 196900, Anchorage, AK 99519
 Email Address: taralyn.stone@alaska.gov
 Telephone: (907) 269-0534 Fax: _____
- Project Coordinator/Contractor:
 Name: Taralyn Stone, Environmental Team Leader
 Address: DOT&PF
 Email Address: taralyn.stone@alaska.gov
 Telephone: (907)269-0534 Fax: _____

B. TYPE AND PURPOSE OF PROJECT: _____

CHANNEL REALIGNMENT OF THE UNNAMED TRIBUTARY TO THE KWIGILLINGOK RIVER

The proposed project consists of airport improvements of the existing Kwigillingok Airport to bring deficiencies up to current State and FAA standards. Project components include: constructing a 3,780 foot long by 120 foot wide lighted runway and safety area with a taxiway, apron, navigational aids, 2 Snow Removal Equipment Buildings (one heated, one unheated), and an access road. Supplemental work includes: providing a haul road and staging area to import barged materials for construction; construction of an ice road during winter months to facilitate work, and realignment of a channel currently eroding the embankment of the existing runway.

The purpose of the proposed project is to improve safety at the airport.

This application covers channel reroute work for the channel currently eroding the existing runway. The channel is an unnamed tributary of the Kwigillingok River, anadromous stream number 335-40-15950.

C. LOCATION OF PROJECT SITE

- Name of River, Stream, or Lake: Unnamed Tributary to the Kwigillingok River,
 or Anadromous Stream No: Kwigillingok River = Stream No. 335-40-15950
- Legal Description: Township 03S Range 81 W
 Meridian SM Section 34 & 35 USGS Quad Map _____
- Plans, Specifications, and Aerial Photograph. [See specific instructions](#)

D. **TIME FRAME FOR PROJECT:** Winter 2015 TO Winter 2017 (mm/dd/yy)

E. **CONSTRUCTION METHODS:**

1. Will the stream be diverted? Yes No
How will the stream be diverted? In the winter, the new stream will be excavated and material will be relocated to fill in a section of the old channel.
How long? Permanently
2. Will stream channelization occur? Yes No
3. Will the banks of the stream be altered or modified? Yes No
Describe: The new channel is V shaped and designed to mimic the existing channel shape with a similar narrow bottom and a combination of 4:1 and 2:1 slopes.
4. List all tracked or wheeled equipment (type and size) that will be used in the stream (in the water, on ice, or in the floodplain): backhoe, excavator, grader, dozer
How long will equipment be in the stream? As needed to complete the work, ~ 3 months
5. a. Will material be removed from the floodplain, bed, stream, or lake? Yes No
Streambed material will likely be excavated. Wetlands along the proposed Channel
Type: Reroute will be excavated and relocated to fill in a section of the old channel.
Amount: 70,000 CY, removed and used to fill in old stream.
b. Will material be removed from below the water table? Yes No
If so, to what depth? 11 feet
Is a pumping operation planned? Yes No
6. Will material (including spoils, debris, or overburden) be deposited in the floodplain, stream, or lake? Yes No
If so, what type? fine sands, silt, embankment, and overburden material
Amount: 70,000 CY, enough to fill in the old channel section
Disposal site location(s): Old Channel Section
7. Will blasting be performed? Yes No
Weight of charges: TBD
Type of substrate: TBD
8. Will temporary fills in the stream or lake be required during construction (e.g., for construction traffic around construction site)? Yes No
9. Will ice bridges be required? Yes No

F. SITE REHABILITATION/RESTORATION PLAN: On a separate sheet present a site rehabilitation/restoration plan. [See specific instructions](#)

G. WATERBODY CHARACTERISTICS:

Width of stream: new = 100', existing= 120' Depth of stream or lake: new=11', existing=10'

Type of stream or lake bottom (e.g., sand, gravel, mud): silt and fine sands, gravel

Stream gradient: 0.06 % (0.0006 ft/ft)

H. HYDRAULIC EVALUATION:

1. Will a structure (e.g., culvert, bridge support, dike) be placed below ordinary high water of the stream? Yes No

If yes, attach engineering drawings or a field sketch, as described in [Step B](#).

For culverts, attach stream discharge data for a mean annual flood (Q=2.3), if available.

If applicable, describe potential for channel changes and/or increased bank erosion:

2. Will more than 25,000 cubic yards of material be removed? Yes No

If yes, attach a written hydraulic evaluation including, at a minimum, the following: potential for channel changes, assessment of increased aufeis (glaciating) potential, assessment of potential for increased bank erosion.

I HEREBY CERTIFY THAT ALL INFORMATION PROVIDED ON OR IN CONNECTION WITH THIS APPLICATION IS TRUE AND COMPLETE TO THE BEST OF MY KNOWLEDGE AND BELIEF.

Signature of Applicant

Date

**Alaska Department of Fish and Game Division of Habitat
Fish Habitat Permit Application: Attachment**

Kwigillingok Airport Improvements

CHANNEL REALIGNMENT

F. SITE REHABILITATION/RESTORATION PLAN

As required by the application instructions (Step F), this plan outlines the precautions taken to insure that fish and other aquatic organisms are protected from adverse impacts. If channel or bank alterations occur, this plan outlines the steps to be taken to restore, rehabilitate, or revegetate the site. Finally, this plan also outlines the precautions to be taken to maintain State Water Quality Standards.

In order to ensure that **fish and aquatic organisms are protected from adverse impacts**, the project's work plan will include the following requirements:

1. Stream realignment work will be conducted in the winter to minimize impact to fish habitat.
2. Construction shall be conducted in a manner to avoid the introduction of sediments, contaminants, or other materials into the waters of the Kwigillingok River tributary (tidal channel) both during and after construction.
3. Should flowing water be discovered during construction, a barrier will be installed below the ordinary high water mark of the river to isolate flowing water from the work area.
4. Erosion prevention will include stabilization of the bank cuts, slopes and fills both during and after construction.
5. No fuel shall be stored along the banks of the Kwigillingok River. Similarly, no vehicles will be fueled or serviced along the banks.

If **channel or bank alterations occur**, the following steps will be taken to restore and rehabilitate the site:

1. Winter construction will allow sufficient prevention of bank or channel alteration. Should open water be discovered, efforts to install a barrier below the ordinary high water mark of the river will be made to isolate flowing water from the work area.
2. All bank cuts, slopes, fills or other exposed earthwork above the tidally flooded waterways will be stabilized to restore the site.
3. Following construction, the embankments and disturbed areas above the tidally flooded waterways will be revegetated with native seed to ensure the alterations are stabilized.

In order to **maintain State Water Quality Standards**, the following step will be taken:

- Winter construction will avoid and minimize sediments from contributing to the turbidity of the channel.
- Revegetation of the embankments, cuts and slopes will occur following construction.

As an added precaution, a copy of the pending permit will be kept on site. Should any unexpected activity arise, and work deviates from this plan, the ADF&G Division of Habitat will be notified. Work will be dependent on the receipt of written approval for the permit amendment before resuming work.

H. HYDRAULIC EVALUATION

As required by the application instructions (Step H), since more than 25,000 cubic yards of material is anticipated to be removed during the channel realignment work, at a minimum, the following need to be described in a hydraulic evaluation:

- Potential for channel changes
- An assessment of increased aufeis (glaciering) potential
- An assessment of potential for increased bank erosion

On behalf of the Department of Transportation and Public Facilities (DOT&PF), Hydraulic Mapping and Modeling hydraulic engineer Ken Karle (CE-9487) prepared a Hydrologic and Hydraulic Report for the Kwigillingok Airport Improvements project. The report describes hydrologic characteristics of Kwigillingok and includes a hydraulic analysis of the preferred design for runway embankment erosion protection.

Specifically, the hydrologist analyzed the reason for bank erosion along the tidal channel currently responsible for eroding the runway. Analyzing the erosion of the existing channel allows assessment of erosion protection along the new channel. Design recommendations for the new channel realignment and erosion protection are included in the report.

For further information and analysis, see the *Kwigillingok Airport Hydrologic and Hydraulic Analysis* (2014). The report is kept on file at DOT&PF and is available upon request.

NOTES:

1. PROPOSED AIRPORT BOUNDARY IS THE PROPOSED AIRPORT ACQUISITION AND INCLUDES THE LAND NEEDED FOR THE FUTURE CROSSWIND RUNWAY.
2. CONSTRUCTION OF THE FUTURE CROSSWIND RUNWAY IS NOT PART OF THIS PROJECT.

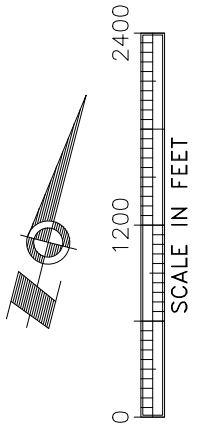
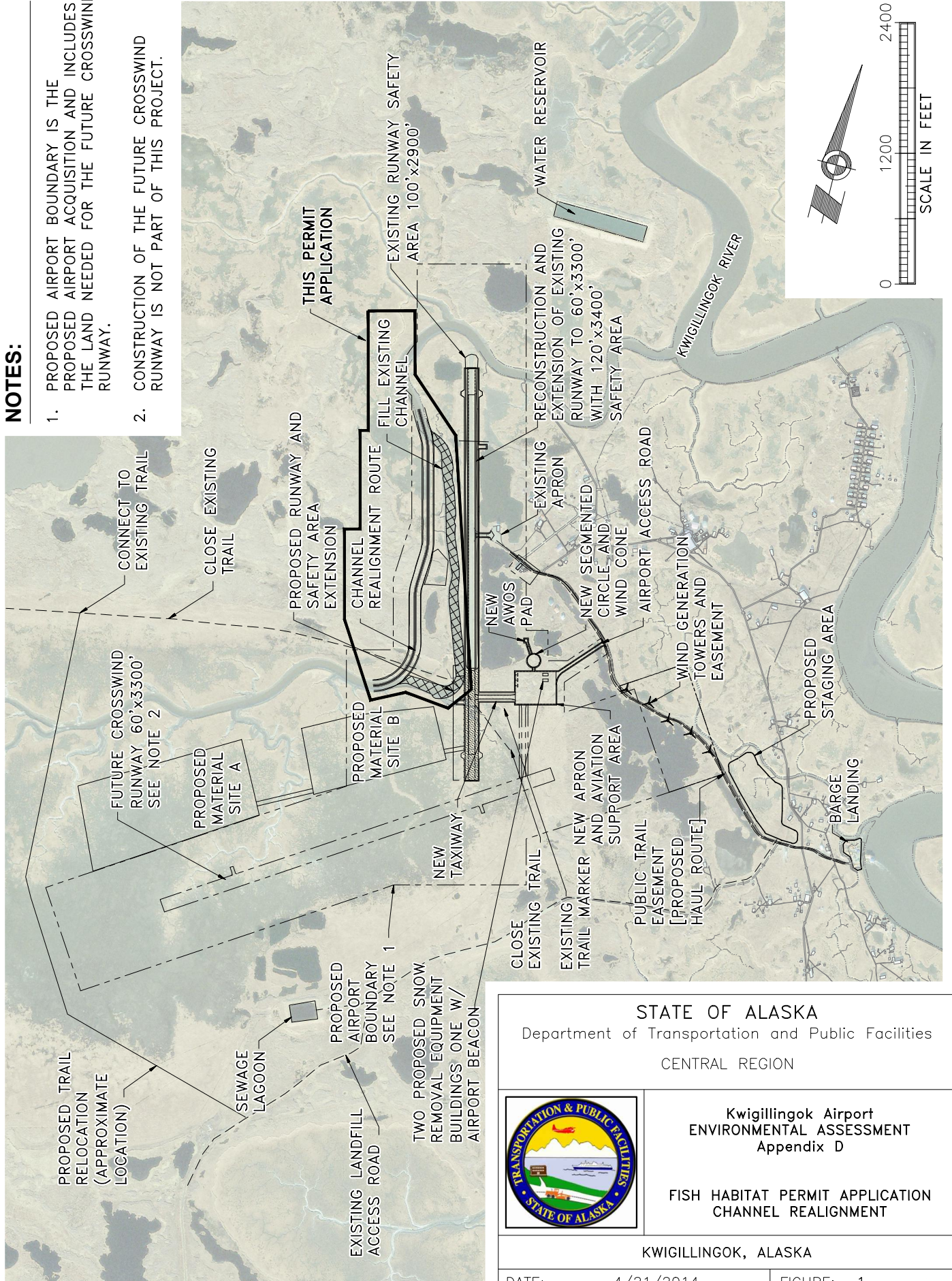

<p>STATE OF ALASKA Department of Transportation and Public Facilities CENTRAL REGION</p>	
 <p>Kwigillingok Airport ENVIRONMENTAL ASSESSMENT Appendix D</p>	
<p>FISH HABITAT PERMIT APPLICATION CHANNEL REALIGNMENT</p>	
<p>KWIGILLINGOK, ALASKA</p>	
DATE:	4/21/2014
FIGURE:	1

Material Site Reclamation Plan

**STATE OF ALASKA DEPARTMENT OF NATURAL RESOURCES
DIVISION OF MINING, LAND AND WATER**

Northern Region
3700 Airport Way
Fairbanks, AK 99709
(907) 451-2740

Southcentral Region
550 W 7th Ave., Suite 900C
Anchorage, AK 99501-3577
(907) 269-8552

Southeast Region
400 Willoughby, #400
P.O. Box 111020
Juneau, AK 99801
(907) 465-3400

**MATERIAL SITE RECLAMATION PLAN OR
LETTER OF INTENT/ANNUAL RECLAMATION STATEMENT
AS 27.19.030 – 27.19.050**

Non-refundable filing fee for reclamation plan: \$100

In accordance with Alaska Statute 27.19, reclamation is required of all mining operations, including sand and gravel extraction. Completion of this form will meet the law's requirements for a **reclamation plan** (see below for filing requirements; due date: at least 45 days before mining is proposed to begin; requires approval by the Division of Mining, Land and Water). Completion of this form will also serve as a **letter of intent** for operations exempt from the plan requirement (due date: before mining begins). No approval is required for a letter of intent, but a miner who files a letter of intent must, before December 31, file an **annual reclamation statement** (Section 8 of this form).

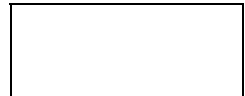

Check applicable box:

A. RECLAMATION PLAN (REQUIRED if the operation will disturb five or more acres this year, OR 50,000 cubic yards, OR if the operation has a cumulative disturbed area of five or more acres)

C. LETTER OF INTENT (less than five acres to be disturbed AND less than 50,000 cubic yards AND less than five acres unreclaimed area)
NOTE: A miner who files a letter of intent is also required to file an annual reclamation statement at the end of the year.

B. RECLAMATION PLAN—VOLUNTARY (for an operation below limits shown in Box A but wanting to qualify for the statewide bonding pool)

THIS RECLAMATION PLAN/LETTER OF INTENT IS FOR CALENDAR YEAR 2015-2016.
(IF YOU CHECKED EITHER BOX A OR B ABOVE AND PROPOSE A MULTI-YEAR PLAN, STATE ALL YEARS COVERED.)

1. MINER INFORMATION (IF THERE IS MORE THAN ONE MINER, ATTACH A LIST OF THE NAMES, ADDRESSES, AND TELEPHONE NUMBERS OF ALL OTHER OWNERS, OPERATORS, OR LEASEHOLDERS OF THE MINING OPERATION)

Alaska Department of Transportation and Public Facilities

NAME OF MINER WHO WILL SERVE AS AGENT FOR NOTICE PURPOSES

PO BOX 196900

ADDRESS (NOTIFY THE DEPARTMENT OF ANY LATER CHANGE OF ADDRESS)

Anchorage	AK	99519	907-269-0531
CITY	STATE	ZIP CODE	TELEPHONE

Kwik Inc., Calista Corporation, and Native Village of Kwigillingok

NAME OF LANDOWNER (IF OTHER THAN MINER) OR PUBLIC LAND MANAGEMENT AGENCY

N/A

FEDERAL OR STATE CASEFILE NUMBER (IF ANY) ASSIGNED TO THE SITE

2. LEGAL DESCRIPTION OF PROPOSED MINING SITE

Section 35	03 South	81 West	Seward
LEGAL SUBDIVISION/ SECTION/ QUARTER-SECTION	TOWNSHIP	RANGE	MERIDIAN

3. DESCRIPTION OF THE MINING OPERATION (IF YOU CHECKED BOX A OR B ON P. 1 OF THIS FORM AND ARE PROPOSING A MULTI-YEAR RECLAMATION PLAN, ATTACH SEPARATE SHEETS AS NEEDED SHOWING ACREAGE TO BE MINED, VOLUME TO BE MINED, AND EXISTING ACREAGE OF MINED AREA FOR EACH YEAR COVERED BY THE PLAN)

- a. 57 acres Total acreage to be mined or disturbed during the year.
- b. 520,000 cu. yds. Estimated total volume to be mined or disturbed, including overburden.
- c. Overburen tundra, sand, silt Type of material (sand, gravel, peat, etc.).
- d. 0 acres Existing acreage of mined area (disturbed area that has not yet been reclaimed, but counting only acreage disturbed after October 15, 1991)

4. DESCRIPTION OF THE RECLAMATION OPERATION

- a. The total acreage that will be reclaimed during the year (or each year, if for a multi-year reclamation plan) is: 57.
- b. Provide a list of equipment (type and quantity) to be used during the reclamation operation. backhoe, grader, hydroseeder, water for re-vegetation, dump truck
- c. A time schedule of reclamation measures shall be included as part of the plan.

The following measures must be considered in preparing and implementing the reclamation plan. Please mark those measures appropriate to your reclamation activity:

- Topsoil that is not promptly redistributed to an area being reclaimed will be separated and stockpiled for future use. This material will be protected from erosion and contamination by acidic or toxic materials and preserved in a condition suitable for later use.
- The area will be backfilled, graded and recontoured using strippings, overburden, and topsoil to a condition that allows for the reestablishment of renewable resources on the site within a reasonable period of time. It will be stabilized to a condition that will allow sufficient moisture to be retained for natural revegetation.
- Stockpiled topsoil will be spread over the reclaimed area to promote natural plant growth that can reasonably be expected to revegetate the area within five years.
- Stream channel diversions will be relocated to a stable location in the flood plain.
- Exploration trenches or pits will be backfilled. Brush piles, vegetation, topsoil, and other organics will be spread on the backfilled surface to inhibit erosion and promote natural revegetation.
- All buildings and structures constructed, used, or improved on land owned by the State of Alaska will be removed, dismantled, or otherwise properly disposed of at the completion of the mining operation.
- Any roads, airstrips or other facilities constructed to provide access to the mining operation shall be reclaimed (unless otherwise authorized) and included in the reclamation plan.
- Peat and topsoil mine operations shall ensure a minimum of two inches of suitable growing medium is left or replaced on the site upon completion of the reclamation activity.

- If extraction occurs within a flood plain, the reclamation activity shall reestablish a stable bed and bank profile such that river currents will not be altered and erosion and deposition patterns will not change.

NOTE: If you propose to use reclamation measures other than those shown above, or if the private landowner or public land manager of the site requires you to use stricter reclamation measures than those shown above, attach a list of those measures to this plan.

5. ALTERNATE POST-MINING LAND USE

- The mining site is public land. The land management agency's land use plan (if any) for post-mining land use is: _____.
- The mining site is public land. As allowed by AS 27.19.030(b), I propose to reclaim it to the following post-mining land use: _____.
- The mining site is private property. The private landowner plans to use it for the following post-mining land use: _____
No post-mining land use is known at this time.

6. ATTACHMENTS

- If the mining operation has additional owners, operators, or leaseholders not shown on p. 1 of this form, attach a list of their names, addresses, and telephone numbers.
- Attach a USGS map at a scale no smaller than 1:63,360 (inch to the mile) showing the general vicinity of the mining operation and the specific property to be mined. Option: If you checked Box C on the first page of this form and the mining site is adjacent to an airport or public highway, state the name of the airport or the name and milepost of the public highway.
- Attach a diagram of the mined area (this term includes the extraction site, stockpile sites, overburden disposal sites, stream diversions, settling ponds, etc.) and the mining operation as a whole (this term includes the roads you plan to build, your power lines, support facilities, etc.). Show and state the number of acres to be mined during the year. (If you checked Box A or B on the first page of this form and your plan covers more than one year, show each year's work.) Show the location corners or property boundaries of the site in relation to the reclamation work and any other areas affected by the operation.
- Attach a list of the equipment (type and quantity) to be used during the reclamation activity.
- A time schedule of events must be attached that includes dates and activities related to this reclamation plan.
- If the site is private land not owned by the miner, attach a signed, notarized statement from the landowner indicating the landowner's consent to the operation. The landowner may also use the consent statement to notify the department that the landowner plans a post-mining land use incompatible with natural revegetation and therefore believes that reclamation to the standard of AS 27.19.020 is not feasible.
- For those miners that are required to file an annual reclamation statement, attach photographs and/or videotapes dated and described as to location of the reclamation activity that was completed.
- If you propose to use reclamation measures other than those listed on this form, or if the private landowner or public land manager of the site requires you to use stricter reclamation measures, attach a list of those measures.

7. **RECLAMATION BONDING** (REQUIRED **ONLY** IF YOU CHECKED BOX A or B ON THE FIRST PAGE OF THIS FORM)

The total acreage of my mining operation that is subject to the bonding requirement for the current year is

57 acres (add acreages stated in Section 3(a) and 3(d) of this form).

The per-acre bond amount is \$750/acre or a total bond amount of \$_____.

Please check the appropriate bonding method that you will apply toward this reclamation plan:

- Participation in the statewide bonding pool.
- Posting a corporate surety bond.
- Posting a personal bond accompanied by a letter of credit, certificate of deposit, or a deposit of cash or gold.
- Posting a bond or financial guarantee with another government agency that has jurisdiction over the mining operation, as allowed by a cooperative management agreement between that agency and the Division of Mining, Land and Water.
- Posting a general performance bond with a state agency that meets the requirements of 11 AAC 97.400(4).

The above reclamation plan/letter of intent and all attachments are correct and complete to the best of my knowledge.

Signature of Miner

Date

AS 27.19.030 and AS 27.19.050 require a miner either to file a reclamation plan for approval or to file a letter of intent followed by an annual reclamation statement. **AS 38.05.035(a) authorizes the director to decide what information is needed to process an application for the sale or use of state land and resources. This information is made a part of the state public land records and becomes public information under AS 40.25.110 and 40.25.120 (unless the information qualifies for confidentiality under AS 38.05.035(a)(9) and confidentiality is requested). Public information is open to inspection by you or any member of the public. A person who is the subject of the information may challenge its accuracy or completeness under AS 44.99.310, by giving a written description of the challenged information, the changes needed to correct it, and a name and address where the person can be reached. False statements made in an application for a benefit are punishable under AS 11.56.210.**

8. **ANNUAL RECLAMATION STATEMENT—REQUIRED** IF YOU FILED A LETTER OF INTENT (CHECKED BOX C ON THE FIRST PAGE) FOR THIS OPERATION. DUE DATE: DECEMBER 31, _____. YOU MUST FILE EVEN IF THE MINING DESCRIBED IN YOUR LETTER OF INTENT DID NOT TAKE PLACE.

This _____ annual reclamation statement is for:
(year)

- a. _____ acres Total acreage mined.
- b. _____ cu. yds. Total volume mined or disturbed, including overburden.
- c. _____ acres Total acreage reclaimed.
- d. _____ acres Cumulative total of unreclaimed acreage.
- e. Reclamation measures that were used (check appropriate measures from Section 4, DESCRIPTION OF THE RECLAMATION OPERATION, and attach list of additional or stricter measures if applicable).

The above annual reclamation statement and all attachments are correct and complete to the best of my knowledge.

Signature of Miner

Date

AS 27.19.030 and AS 27.19.050 require a miner either to file a reclamation plan for approval or to file a letter of intent followed by an annual reclamation statement. This information is made a part of the state public land records and becomes public information under AS 40.25.110 and 40.25.120 (unless the information qualifies for confidentiality under AS 38.05.035(a)(9) and confidentiality is requested). Public information is open to inspection by you or any member of the public. A person who is the subject of the information may challenge its accuracy or completeness under AS 44.99.310, by giving a written description of the challenged information, the changes needed to correct it, and a name and address where the person can be reached. False statements made in an application for a benefit are punishable under AS 11.56.210.

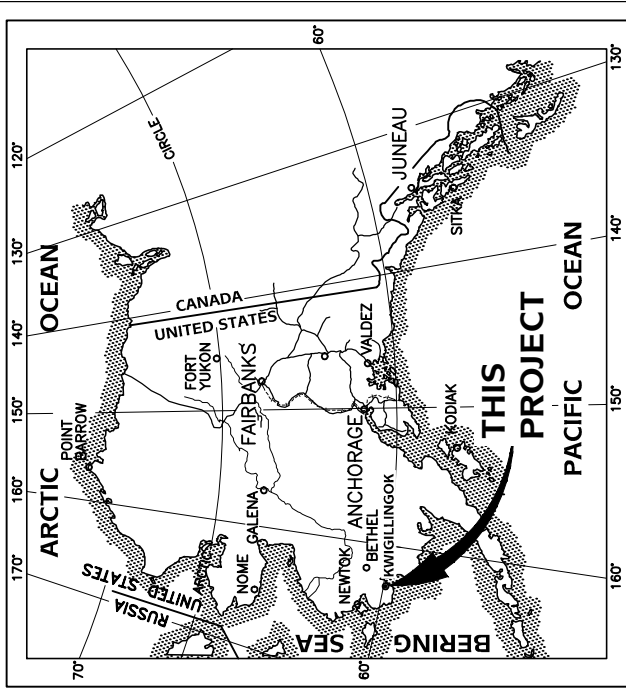

LOCATION MAP

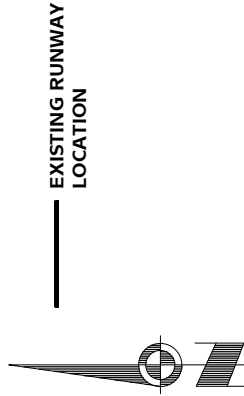

**SEC 26, 27, 34, 35, T3S, R81W;
SEWARD MERIDIAN**

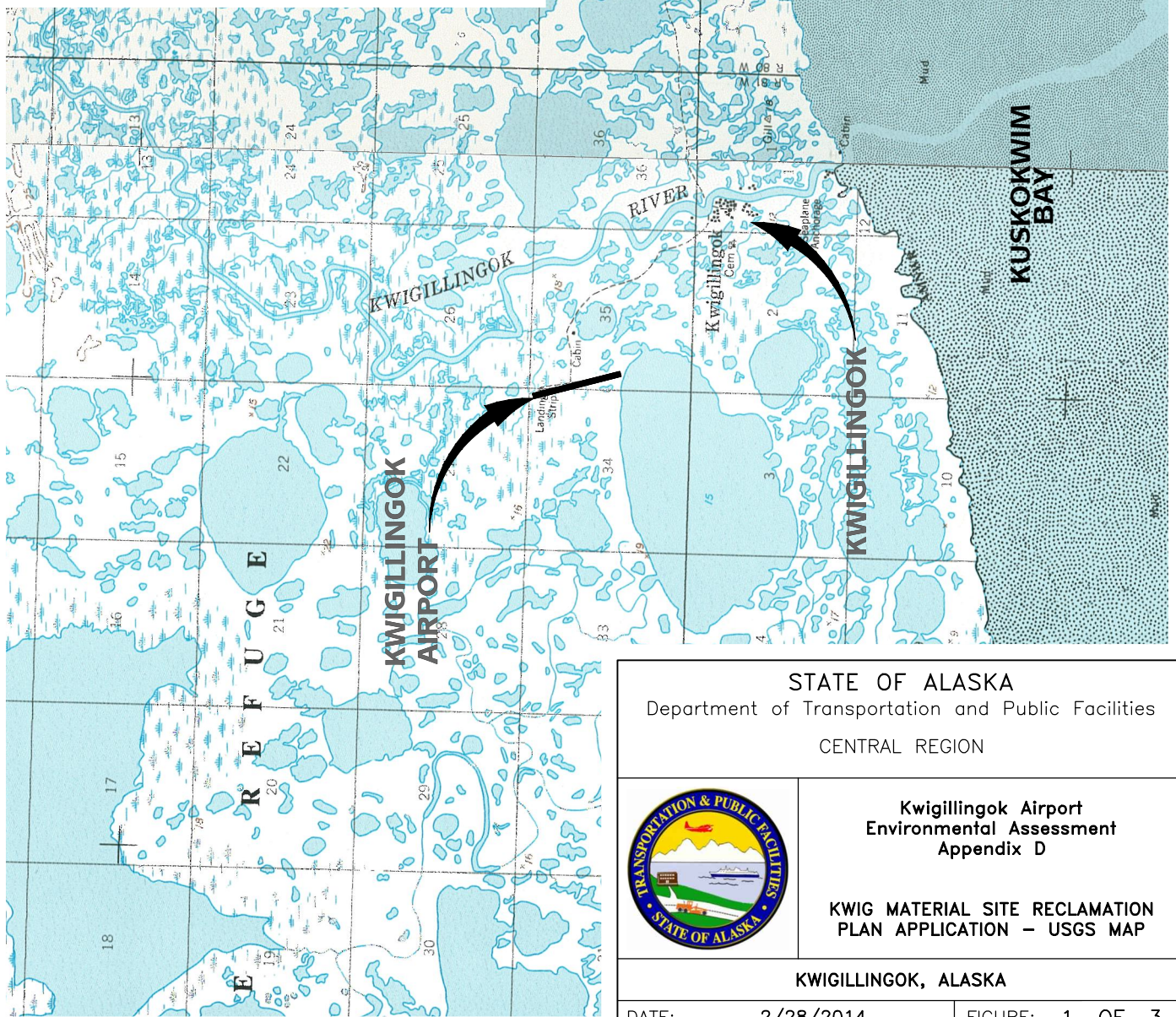
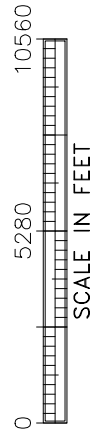

STATE OF ALASKA Department of Transportation and Public Facilities CENTRAL REGION	
	Kwigillingok Airport Environmental Assessment Appendix D
KWIG MATERIAL SITE RECLAMATION PLAN APPLICATION - USGS MAP	
KWIGILLINGOK, ALASKA	
DATE:	2/28/2014
FIGURE:	1 OF 3

NOTES:

1. PROPOSED AIRPORT BOUNDARY IS THE PROPOSED AIRPORT ACQUISITION AND INCLUDES THE LAND NEEDED FOR THE FUTURE CROSSWIND RUNWAY.
2. CONSTRUCTION OF THE FUTURE CROSSWIND RUNWAY IS NOT PART OF THIS PROJECT.

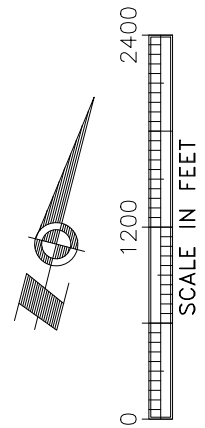
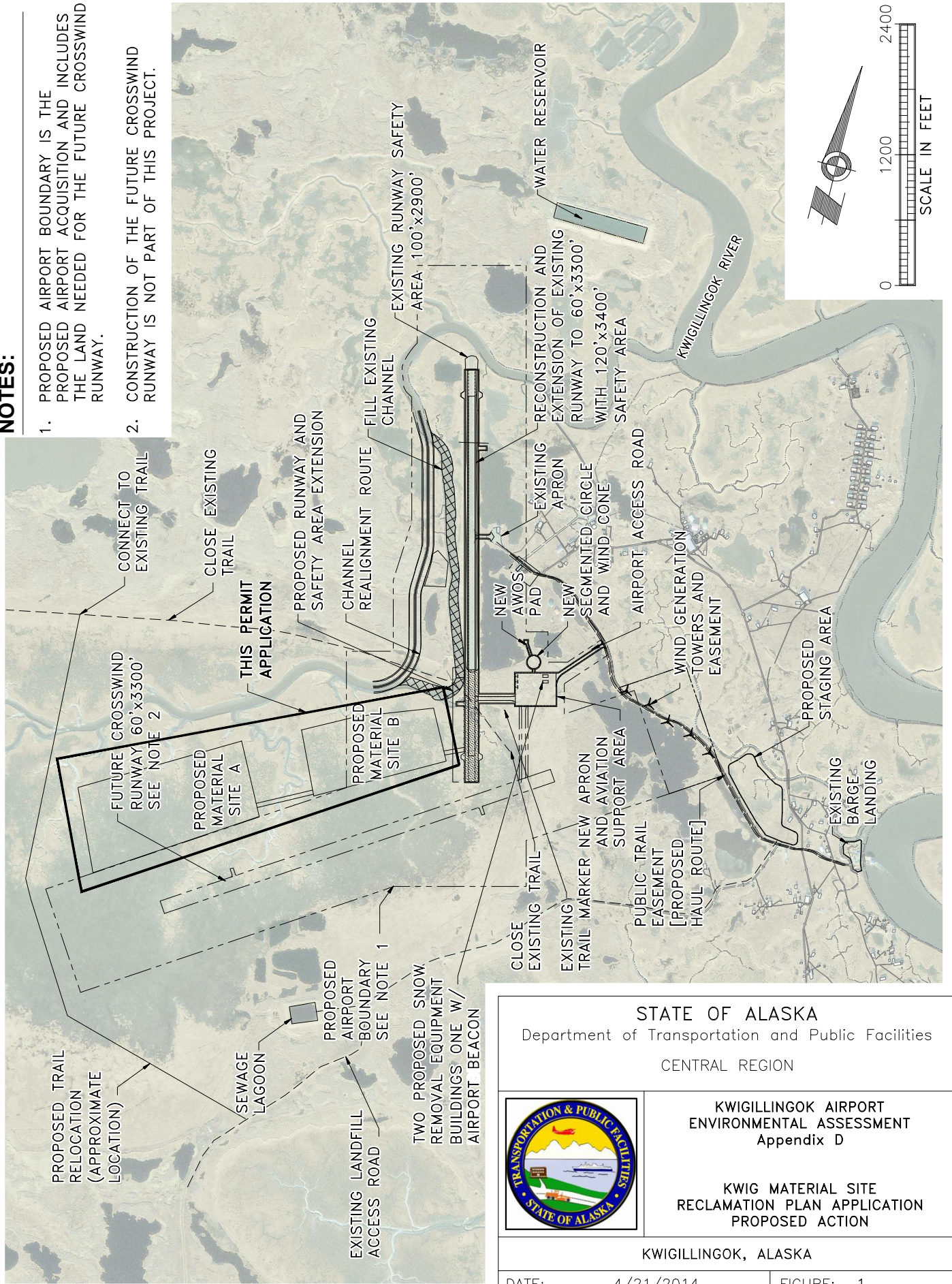

<p>STATE OF ALASKA Department of Transportation and Public Facilities CENTRAL REGION</p>	
	<p>KWIGILLINGOK AIRPORT ENVIRONMENTAL ASSESSMENT Appendix D</p>
<p>KWIG MATERIAL SITE RECLAMATION PLAN APPLICATION PROPOSED ACTION</p>	
<p>KWIGILLINGOK, ALASKA</p>	
DATE:	4/21/2014
FIGURE:	1

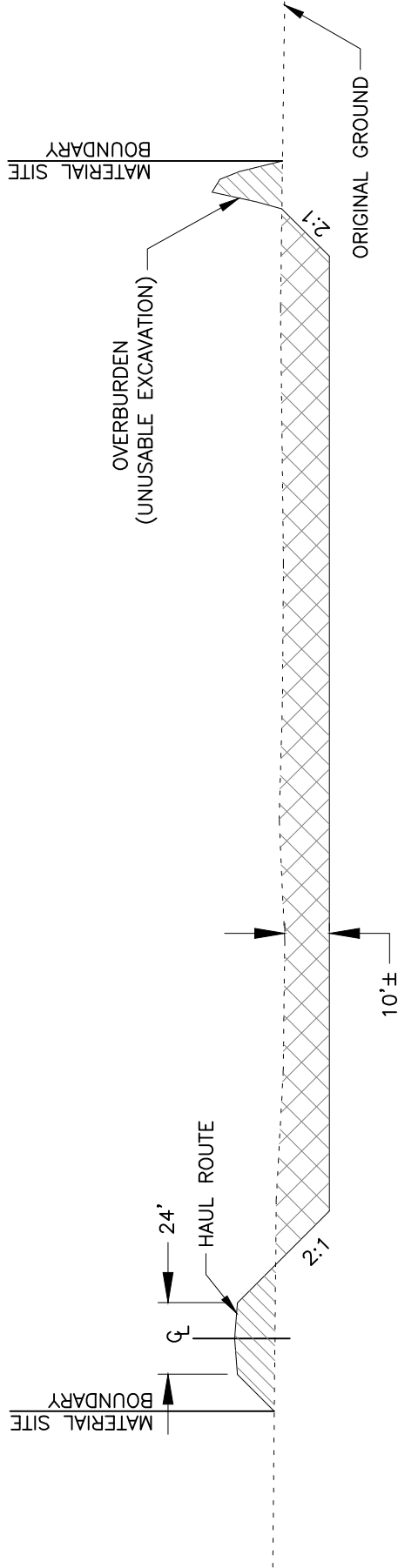

MATERIAL SITE AND HAUL ROUTE TYPICAL SECTION

-  FILL IN WETLANDS
-  EXCAVATION IN WETLANDS

<p>STATE OF ALASKA Department of Transportation and Public Facilities CENTRAL REGION</p>	
	<p>Kwigillingok Airport Environmental Assessment Appendix D</p>
<p>TYPICAL SECTION MATERIAL SITES A & B</p>	
<p>KWIGILLINGOK, ALASKA</p>	
DATE:	2/28/2014
FIGURE:	3 OF 3

Temporary Water Use

DIVISION OF MINING, LAND AND WATER
WATER RESOURCES SECTION

www.dnr.state.ak.us/mlw/water/index.htm



Anchorage Office 550 West 7 th Avenue, Suite 1020 Anchorage, AK 99501-3562 (907) 269-8600 Fax: (907) 269-8947	Juneau Office PO Box 111020 400 Willoughby Avenue Juneau, AK 99811-1020 (907) 465-3400 Fax: (907) 586-2954	Fairbanks Office 3700 Airport Way Fairbanks, AK 99709-4699 (907) 451-2790 Fax: (907) 451-2703	For ADNR Use Only Date/Time Stamp
For ADNR Use Only TWUP #	For ADNR Use Only CID #	For ADNR Use Only Receipt Type WR	

APPLICATION FOR TEMPORARY USE OF WATER

INSTRUCTIONS

1. Complete one application for each project including up to five water sources (incomplete applications will not be accepted).
2. Attach legible map that includes meridian, township, range, and section lines such as a USGS topographical quadrangle or subdivision plat. Indicate water withdrawal point(s), location(s) of water use, and point(s) of return flow or discharge (if applicable).
3. Attach sketch, photos, plans of water system, or project description (if applicable).
4. Attach driller's well log for drilled wells (if available).
5. Attach copy of ADNR fish habitat permit (if applicable).
6. Attach completed Coastal Project Questionnaire (if applicable - see page 4).
7. Submit non-refundable fee (see page 4).

APPLICANT INFORMATION

Project Name _____

Organization Name (if applicable) _____

Agent or Consultant Name (if applicable) _____

Individual Name (if applicable) _____

Individual Co-applicant Name (if applicable) _____

Mailing Address _____

City _____

State _____

Zip Code _____

Daytime Phone Number _____

Alternate Phone Number (optional) _____

Fax Number (if available) _____

E-Mail Address (optional) _____

<i>PROPERTY DESCRIPTIONS</i>						
Location of Water Use						
Project Area (e.g. milepost range, place name, survey number)	Meridian	Township	Range	Section	Quarter Sections	
					1/4	1/4
					1/4	1/4
Location of Water Source						
Geographic Name of Water Body or Well Depth	Meridian	Township	Range	Section	Quarter Sections	
					1/4	1/4
					1/4	1/4
					1/4	1/4
					1/4	1/4
					1/4	1/4
Location of Water Return Flow or Discharge (if applicable)						
Geographic Name of Water Body or Well Depth	Meridian	Township	Range	Section	Quarter Sections	
					1/4	1/4
					1/4	1/4

<i>METHOD OF TAKING WATER</i>	
Pump Pump Intake _____ Inches Pump Output _____ GPM	Hours Working _____ Hours/Day Length of Pipe _____ Feet (from pump to point of use)
Gravity Pipe Diameter _____ Inches Head _____ Feet	Length of Pipe _____ Feet (take point to point of use)
Ditch L _____ H _____ W _____ Feet	Diversion Rate _____ <input type="checkbox"/> GPM or <input type="checkbox"/> CFS
Reservoir L _____ H _____ W _____ Feet	Water Storage _____ Acre-feet
Dam L _____ H _____ W _____ Feet	Water Storage _____ Acre-feet

<i>AMOUNT OF WATER</i>					
Purpose of Water Use	Quantity of Water			Season of Use	
	Maximum Withdrawal Rate	Total Daily Amount	Total Seasonal Amount	Date Work Will Start	Date Work Will be Completed
Project Totals				Total years needed: _____	

<i>PROJECT DESCRIPTION</i>
What alternative water sources are available to your project should a portion of your requested diversion be excluded because of water shortage or public interest concerns?
Are there any surface water bodies or water wells at or near your site(s) that could be affected by the proposed activity? If yes, list any ground water monitoring programs going on at or near the sites, any water shortages or water quality problems in the area, and any information about the water table, if known.
Briefly describe the type and size of equipment used to withdraw and transport water, including the amount of water the equipment uses or holds.
Briefly describe what changes at the project site and surrounding area will occur or are likely to occur because of construction or operation of your project (e.g. public access, streambed alteration, trenching, grading, excavation).
Briefly describe land use around the water take, use, and return flow points (e.g. national park, recreational site, residential).
Will project be worked in phases? State reason for completion date.
Briefly describe your entire project: _____ _____ _____
(Attach extra page if needed.)

11 AAC 93.220 sets out the required information on the application and authorizes the department to consider any other information needed to process an application for a temporary use of water. This information is made a part of the state public water records and becomes public information under AS 40.25.110 and 40.25.120. Public information is open to inspection by you or any member of the public. A person who is the subject of the information may challenge its accuracy or completeness under AS 44.99.310, by giving a written description of the challenged information, the changes needed to correct it, and a name and address where the person can be reached. False statements made in an application for a benefit are punishable under AS 11.56.210.

SIGNATURE	
The information presented in this application is true and correct to the best of my knowledge. I understand that no water right or priority is established per 11 AAC 93.210-220, that the water used remains subject to appropriation by others, and that a temporary water use authorization may be revoked if necessary to protect the water rights of other persons or the public interest.	
_____ Signature	_____ Date
_____ Name (please print)	_____ Title (if applicable)

REFERENCES				
Measurement Units GPD = gallons per day CFS = cubic feet per second GPM = gallons per minute AF = acre-feet AFY = acre-feet per year (325,851 gallons/year) AFD = acre-feet per day (325,851 gallons/day) MGD = million gallons per day				
Conversion Table				
<u>5,000 GPD=</u>	<u>30,000 GPD=</u>	<u>100,000 GPD=</u>	<u>500,000 GPD=</u>	<u>1,000,000 GPD=</u>
0.01 CFS	0.05 CFS	0.2 CFS	0.8 CFS	1.5 CFS
3.47 GPM	20.83 GPM	69.4 GPM	347. 2 GPM	694.4 GPM
5.60 AFY	33.60 AFY	112.0 AFY	560.1 AFY	1120.1 AFY
0.2 AFD	0.09 AFD	0.3 AFD	1.5 AFD	3.1 AFD
0.01 MGD	0.03 MGD	0.1 MGD	0.5 MGD	1.0 MGD
Fee required by regulation 11 AAC 05.010(a)(8)				
<ul style="list-style-type: none"> • \$350 for all uses of water from up to five water sources Make checks payable to "Department of Natural Resources".				
Coastal Zone				
If this appropriation is within the Coastal Zone, and you are planning to use more than 1,000 GPD from a surface water source or 5,000 GPD from a subsurface water source, you need to submit a completed Coastal Project Questionnaire with this application. For more information on the Coastal Zone, contact the Office of Project Management and Permitting; Anchorage 269-7470, Juneau 465-3562, www.dnr.state.ak.us/acmp/ .				

PROJECT DESCRIPTION For Temporary Water Use Permit Application

The proposed action is to improve the existing airport to meet DOT&PF and FAA standards for a Community Class airport. The improvements would include the following components, as illustrated on Figure 1:

- Expand the existing runway to 3,300 feet by 60 feet. The total runway and safety area dimensions would be 3,780 feet by 120 feet.
- Construct a 35-foot wide new taxiway to the apron. The total width of the taxiway safety area would be 79 feet (Airplane Design Group II, Taxiway Design Group 2); the larger safety area allows for snow removal and occasional operations by larger aircraft.
- Construct a new 374-foot by 300-foot apron and aviation support area.
- Build two SREBs on the aviation support area (one heated and one for cold storage).
- Improve runway and taxiway lighting to include Medium Intensity Runway and Taxiway Lighting (MIRL), and two pads for Precision Approach Path Indicator (PAPI) lights, and a pad for the AWOS.
- Install wind cones, a segmented circle, and a rotating beacon to aid navigation.
- Build a 24-foot-wide access road between the apron and the main road connecting to the community.
- Acquire approximately 267.3 acres for the runway improvements, future crosswind runway, and access road.
- Install an overhead power line to power the new SREB.

Work required to facilitate the proposed action includes the realignment of a tidal channel that has been responsible for eroding the ground alongside the runway and improvements to an existing trail to provide a haul road for construction.

In order to construct the proposed action, the contractor would need to develop two material sites (Material Sites A and B; Figure 7) and establish a connecting access road from the runway area to the material sites. A haul route from the Kwigillingok River to the airport is needed; this can be provided by improving an existing public easement trail (typical section illustrated on Figure 8). Additionally, the contractor would need a staging area for imported gravel and surface course material.

NOTES:

1. PROPOSED AIRPORT BOUNDARY IS THE PROPOSED AIRPORT ACQUISITION AND INCLUDES THE LAND NEEDED FOR THE FUTURE CROSSWIND RUNWAY.
2. CONSTRUCTION OF THE FUTURE CROSSWIND RUNWAY IS NOT PART OF THIS PROJECT.

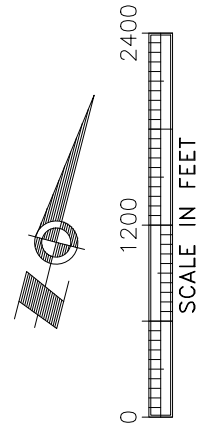
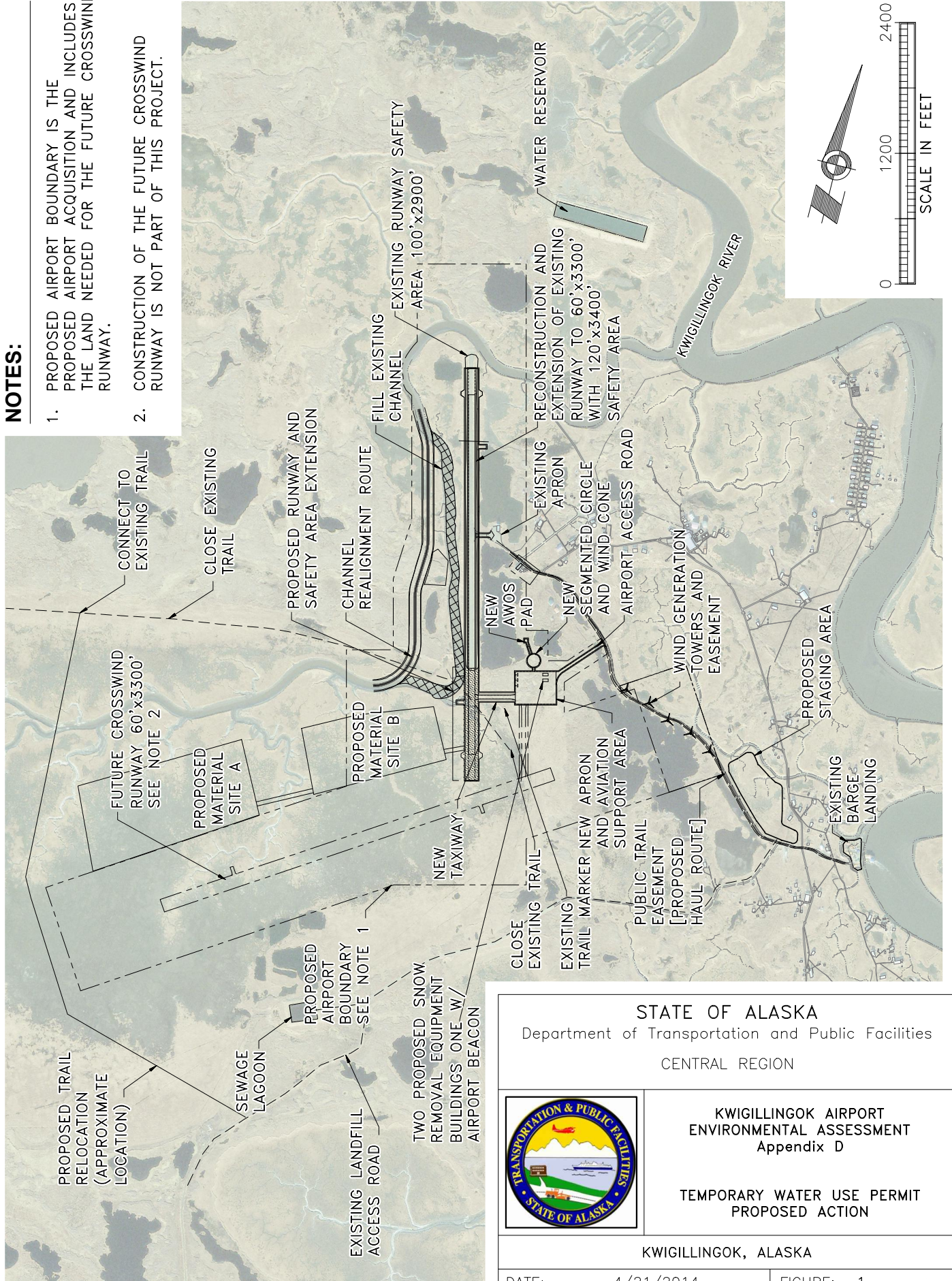

<p>STATE OF ALASKA Department of Transportation and Public Facilities CENTRAL REGION</p>	
	<p>KWIGILLINGOK AIRPORT ENVIRONMENTAL ASSESSMENT Appendix D</p>
<p>TEMPORARY WATER USE PERMIT PROPOSED ACTION</p>	
<p>KWIGILLINGOK, ALASKA</p>	
<p>DATE: 4/21/2014</p>	<p>FIGURE: 1</p>