



U.S. Department
of Transportation
**Federal Highway
Administration**

November 19, 2019

1200 New Jersey Ave., SE
Washington, D.C. 20590

In Reply Refer To:
HSST-1/B-327

Mr. Jeff Jeffers
State of Alaska Department of Transportation and Public Facilities
3132 Channel Drive
Juneau, AK 99811-2500

Dear Mr. Jeffers:

This letter is in response to your June 14, 2019 request for the Federal Highway Administration (FHWA) to review a roadside safety device, hardware, or system for eligibility for reimbursement under the Federal-aid highway program. This FHWA letter of eligibility is assigned FHWA control number B-327 and is valid until a subsequent letter is issued by FHWA that expressly references this device.

Decision

The following device is eligible within the length-of-need, with details provided in the form which is attached as an integral part of this letter:

- 2019 MASH 2-Tube Bridge Rail

Scope of this Letter

To be found eligible for Federal-aid funding, new roadside safety devices should meet the crash test and evaluation criteria contained in the American Association of State Highway and Transportation Officials' (AASHTO) Manual for Assessing Safety Hardware (MASH). However, the FHWA, the Department of Transportation, and the United States Government do not regulate the manufacture of roadside safety devices. Eligibility for reimbursement under the Federal-aid highway program does not establish approval, certification or endorsement of the device for any particular purpose or use.

This letter is not a determination by the FHWA, the Department of Transportation, or the United States Government that a vehicle crash involving the device will result in any particular outcome, nor is it a guarantee of the in-service performance of this device. Proper manufacturing, installation, and maintenance are required in order for this device to function as tested.

This finding of eligibility is limited to the crashworthiness of the system and does not cover other structural features, nor conformity with the Manual on Uniform Traffic Control Devices.

Eligibility for Reimbursement

Based solely on a review of crash test results and certifications submitted by the manufacturer, and the crash test laboratory, FHWA agrees that the device described herein meets the crash test and evaluation criteria of the AASHTO's MASH. Therefore, the device is eligible for reimbursement under the Federal-aid highway program if installed under the range of tested conditions.

Name of system: 2019 MASH 2-Tube Bridge Rail

Type of system: Longitudinal Barrier

Test Level: MASH Test Level 4 (TL4)

Testing conducted by: TamTI

Date of request: July 16, 2019

FHWA concurs with the recommendation of the accredited crash testing laboratory as stated within the attached form.

Full Description of the Eligible Device

The device and supporting documentation, including reports of the crash tests or other testing done, videos of any crash testing, and/or drawings of the device, are described in the attached form.

Notice

This eligibility letter is issued for the subject device as tested. Modifications made to the device are not covered by this letter. Any modifications to this device should be submitted to the user (i.e., state DOT) as per their requirements.

You are expected to supply potential users with sufficient information on design, installation and maintenance requirements to ensure proper performance.

You are expected to certify to potential users that the hardware furnished has the same chemistry, mechanical properties, and geometry as that submitted for review, and that it will meet the test and evaluation criteria of AASHTO's MASH.

Issuance of this letter does not convey property rights of any sort or any exclusive privilege. This letter is based on the premise that information and reports submitted by you are accurate and correct. We reserve the right to modify or revoke this letter if: (1) there are any inaccuracies in the information submitted in support of your request for this letter, (2) the qualification testing was flawed, (3) in-service performance or other information reveals safety problems, (4) the system is significantly different from the version that was crash tested, or (5) any other information indicates that the letter was issued in error or otherwise does not reflect full and complete information about the crashworthiness of the system.

Standard Provisions

- To prevent misunderstanding by others, this letter of eligibility designated as FHWA control number B-327 shall not be reproduced except in full. This letter and the test documentation upon which it is based are public information. All such letters and documentation may be reviewed upon request.
- This letter shall not be construed as authorization or consent by the FHWA to use, manufacture, or sell any patented system for which the applicant is not the patent holder.
- This FHWA eligibility letter is not an expression of any Agency view, position, or determination of validity, scope, or ownership of any intellectual property rights to a specific device or design. Further, this letter does not impute any distribution or licensing rights to the requester. This FHWA eligibility letter determination is made based solely on the crash-testing information submitted by the requester. The FHWA reserves the right to review and revoke an earlier eligibility determination after receipt of subsequent information related to crash testing.

Sincerely,

A handwritten signature in blue ink that reads "Michael S. Griffith". The signature is written in a cursive style with a large initial "M".

Michael S. Griffith
Director, Office of Safety Technologies
Office of Safety

Enclosures

Request for Federal Aid Reimbursement Eligibility of Highway Safety Hardware

Submitter	Date of Request:	June 14, 2019	<input checked="" type="radio"/> New <input type="radio"/> Resubmission
	Name:	Jeff Jeffers	
	Company:	State of Alaska Department of Transportation and Public Facilities	
	Address:	3132 Channel Drive, Juneau, AK 99811-2500	
	Country:	United States of America	
	To:	Michael S. Griffith, Director FHWA, Office of Safety Technologies	

I request the following devices be considered eligible for reimbursement under the Federal-aid highway program.

Device & Testing Criterion - Enter from right to left starting with Test Level

!-!-!

System Type	Submission Type	Device Name / Variant	Testing Criterion	Test Level
'B': Rigid/Semi-Rigid Barriers (Roadside, Median, Bridge Railings)	<input checked="" type="radio"/> Physical Crash Testing <input type="radio"/> Engineering Analysis	2019 MASH 2-Tube Bridge Rail	AASHTO MASH	TL4

By submitting this request for review and evaluation by the Federal Highway Administration, I certify that the product(s) was (were) tested in conformity with the AASHTO Manual for Assessing Safety Hardware and that the evaluation results meet the appropriate evaluation criteria in the MASH.

Individual or Organization responsible for the product:

Contact Name:	Jeff Jeffers	Same as Submitter <input checked="" type="checkbox"/>
Company Name:	State of Alaska Department of Transportation and Public Facilities	Same as Submitter <input checked="" type="checkbox"/>
Address:	3132 Channel Drive, Juneau, AK 99811-2500	Same as Submitter <input checked="" type="checkbox"/>
Country:	United States of America	Same as Submitter <input checked="" type="checkbox"/>
Enter below all disclosures of financial interests as required by the FHWA 'Federal-Aid Reimbursement Eligibility Process for Safety Hardware Devices' document.		
Texas A&M Transportation Institute (TTI) was contracted by the State of Alaska Department of Transportation and Public Facilities to perform full-scale crash testing of the 2019 MASH 2-Tube Bridge Rail. There are no shared financial interests in the 2019 MASH 2-Tube Bridge Rail by TTI, or between the State of Alaska Department of Transportation and Public Facilities and TTI, other than costs involved in the actual crash tests and reports for this submission to FHWA.		

PRODUCT DESCRIPTION

<input checked="" type="radio"/> New Hardware or Significant Modification	<input type="radio"/> Modification to Existing Hardware	
<p>The 2019 MASH 2-Tube Bridge Rail test installation was 154 ft long, and consisted of a reinforced concrete cantilevered deck and curb, with two 2-inch wide joints extending through both the curb and the deck. The curb was 10 inches tall, with a 4-inch thick lift of grout, yielding a 6-inch tall traffic side face. A 2-sack grout mix was used to simulate asphalt which is typically used on the bridge applications. The curb was 18 inches wide at the base, and 17 inches wide at the top, with the traffic side face sloping 1 inch toward the field side. Anchor bolts were cast in the deck and extended through the curb.</p> <p>Sixteen fabricated steel posts were longitudinally spaced on 10-foot centers, beginning at 24 inches from each end of the concrete curb. Two steel rectangular HSS rail elements spanned the posts, and extended past them at each end of the installation. The tops of the rails were located 24 inches and 38 inches above grade (i.e. the grout on the concrete deck).</p>		
<h3>CRASH TESTING</h3>		
<p>By signature below, the Engineer affiliated with the testing laboratory, agrees in support of this submission that all of the critical and relevant crash tests for this device listed above were conducted to meet the MASH test criteria. The Engineer has determined that no other crash tests are necessary to determine the device meets the MASH criteria.</p>		
Engineer Name:	William F. Williams	
Engineer Signature:	William Williams	Digitally signed by William Williams Date: 2019.07.09 16:22:37 -05'00'
Address:	TTI, TAMU 3135 College Station, TX 77843-3135	Same as Submitter <input type="checkbox"/>
Country:	United States of America	Same as Submitter <input type="checkbox"/>

A brief description of each crash test and its result:

Required Test Number	Narrative Description	Evaluation Results
4-10 (1100C)	<p>Test 4-10 involves an 1100C vehicle impacting the test article at a target impact speed of 62 mi/h and target angle of 25°. The target CIP for the left corner of the front bumper was 3.6 ft upstream of the centerline of Post #13.</p> <p>The results of the test conducted on December 14, 2018, are found in TTI Test Report No. 608331-1A, 2, 3. The test vehicle was traveling at an impact speed of 62.5 mi/h as it made contact with the 2019 MASH 2-Tube Bridge Rail 3.5 ft upstream of the centerline of Post #13 and at an impact angle of 25.3°. After loss of contact with the barrier, the vehicle came to rest 140 ft downstream of the impact point and 11 ft toward the field side.</p> <p>The 2019 MASH 2-Tube Bridge Rail contained and redirected the 1100C vehicle. The vehicle did not penetrate, underride, or override the installation. The vehicle exited within the exit box criteria defined in MASH. Maximum dynamic deflection during the test was 2.8 inches. Maximum permanent deformation was 1 inch. Working width was 8.5 inches.</p> <p>Although slight spalling of the concrete occurred near Post #13, no detached elements, fragments, or other debris were present to penetrate, or to show potential for penetrating, the occupant compartment, or to present undue hazard for others in the area.</p> <p>The 1100C vehicle remained upright during and after the collision event. Maximum roll and pitch angles were 5° and 5°, respectively.</p> <p>Longitudinal OIV was 30.2 ft/s and lateral OIV was 30.8 ft/s. Maximum longitudinal occupant ridedown acceleration was 15.3 g, and maximum lateral occupant ridedown acceleration was 6.3 g. Occupant risk factors were within the maximum limits specified in MASH.</p> <p>Maximum exterior crush to the vehicle was 11.0 inches in the side plane in the front plane at the left front corner at bumper height. Maximum occupant compartment deformation was 4.0 inches in the left front firewall area.</p> <p>The 2019 MASH 2-Tube Bridge Rail performed acceptably for MASH test 4-10.</p>	PASS

Required Test Number	Narrative Description	Evaluation Results
4-11 (2270P)	<p>Test 4-11 involves a 2270P vehicle impacting the test article at a target impact speed of 62 mi/h and target angle of 25°. The target CIP for the left corner of the front bumper was 4.3 ft upstream of the centerline of Post #9.</p> <p>The results of the test conducted on December 12, 2018, are found in TTI Test Report No. 608331-1A, 2, 3. The test vehicle was traveling at an impact speed of 62.9 mi/h as it made contact with the 2019 MASH 2-Tube Bridge Rail 4.2 ft upstream of the centerline of Post #9 and at an impact angle of 24.9°. After loss of contact with the barrier, the vehicle came to rest 230 ft downstream of the impact point and in-line with the rail.</p> <p>The 2019 MASH 2-Tube Bridge Rail contained and redirected the 2270P vehicle. The vehicle did not penetrate, underride, or override the installation. The vehicle exited within the exit box criteria defined in MASH.</p> <p>Maximum dynamic deflection during the test was 7.1 inches. Maximum permanent deformation was 2.0 inches. Working width was 20.2 inches.</p> <p>Although some spalling of the concrete curb and deck occurred on the field side, no detached elements, fragments, or other debris were present to penetrate, or to show potential for penetrating, the occupant compartment, or to present undue hazard for others in the area. The 2270P vehicle remained upright during and after the collision event. Maximum roll and pitch angles were 5° and 3°, respectively.</p> <p>Longitudinal OIV was 16.7 ft/s and lateral OIV was 29.5 ft/s.</p> <p>Maximum longitudinal occupant ridedown acceleration was 8.2 g and maximum lateral occupant ridedown acceleration was 13.6 g. Occupant risk factors were within the preferred limits specified in MASH.</p> <p>Maximum exterior crush to the vehicle was 11.0 inches in the front plane at the left front corner at bumper height. Maximum occupant compartment deformation was 0.5 inch in the left front firewall area.</p> <p>The 2019 MASH 2-Tube Bridge Rail performed acceptably for MASH test 4-11.</p>	PASS

4-12 (10000S)	<p>Test 4-12 involves a 10000S vehicle impacting the test article at a target impact speed of 56 mi/h and target angle of 15°. The target CIP for the left corner of the front bumper was 5.0 ft upstream of centerline of Post #5.</p> <p>The results of the test conducted on December 10, 2018, are found in TTI Test Report No. 608331-1A, 2, 3. The test vehicle was traveling at an impact speed of 57.4 mi/h as it made contact with the 2019 MASH 2-Tube Bridge Rail 4.6 ft upstream of the centerline of Post #5 and at an impact angle of 15.5°. After loss of contact with the barrier, the vehicle came to rest 232 ft downstream of the impact point and 7 ft toward the field side.</p> <p>The 2019 MASH 2-Tube Bridge Rail contained and redirected the 10000S vehicle. The vehicle did not penetrate, underide, or override the installation. The vehicle exited within the exit box criteria defined in MASH.</p> <p>Maximum dynamic deflection during the test was 3.0 inches. Maximum permanent deformation was 2.0 inches. Working width was 56.7 inches.</p> <p>No detached elements, fragments, or other debris were present to penetrate or to show potential for penetrating the occupant compartment, or to present undue hazard for others in the area.</p> <p>The 10000S vehicle remained upright during and after the collision event. Maximum roll and pitch angles were 19° and 9°, respectively.</p> <p>Longitudinal OIV was 6.2 ft/s, and lateral OIV was 12.1 ft/s. Maximum longitudinal occupant ridedown acceleration was 3.0 g, and maximum lateral occupant ridedown acceleration was 6.8 g.</p> <p>Maximum exterior crush to the vehicle was 12.0 inches in the side plane at the left front corner at bumper height. Maximum occupant compartment deformation was 5.5 inches in the left floor pan area.</p> <p>The 2019 MASH 2-Tube Bridge Rail performed acceptably for MASH test 4-12.</p>	PASS
---------------	--	------

4-20 (1100C)	Test for transition is not applicable for this bridge barrier system	Non-Relevant Test, not conducted
4-21 (2270P)	Test for transition is not applicable for this bridge barrier system	Non-Relevant Test, not conducted
4-22 (10000S)	Test for transition is not applicable for this bridge barrier system	Non-Relevant Test, not conducted

Full Scale Crash Testing was done in compliance with MASH by the following accredited crash test laboratory (cite the laboratory's accreditation status as noted in the crash test reports.):

Laboratory Name:	Texas A&M Transportation Institute Proving Ground	
Laboratory Signature:	Digitally signed by Darrell L. Kuhn 'Date: 2019.07.08 17:22:21 -05'00 	
Address:	TTI, TAMU 3135, College Station, TX 77843-3135	Same as Submitter <input type="checkbox"/>
Country:	United States of America	Same as Submitter <input type="checkbox"/>
Accreditation Certificate Number and Dates of current Accreditation period :	ISO 17025-2017 Laboratory A2LA Certificate Number: 2821.01 Valid To: April 30, 2021	

Submitter Signature*: Jeff. C. Jeffers

Digitally signed by Jeff. C. Jeffers
DN: cn=Jeff. C. Jeffers, o=Alaska Department
of Transportation and Public Facilities, ou,
email=jeff.jeffers@alaska.gov, c=US
Date: 2019.07.09 13:52:19 -0800

Submit Form

ATTACHMENTS

Attach to this form:

- 1) Additional disclosures of related financial interest as indicated above.
- 2) A copy of the full test report, video, and a Test Data Summary Sheet for each test conducted in support of this request.
- 3) A drawing or drawings of the device(s) that conform to the Task Force-13 Drawing Specifications [[Hardware Guide Drawing Standards](#)]. For proprietary products, a single isometric line drawing is usually acceptable to illustrate the product, with detailed specifications, intended use, and contact information provided on the reverse. Additional drawings (not in TF-13 format) showing details that are relevant to understanding the dimensions and performance of the device should also be submitted to facilitate our review.

FHWA Official Business Only:

Eligibility Letter		
Number	Date	Key Words

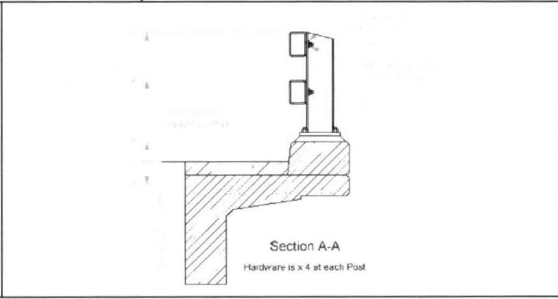
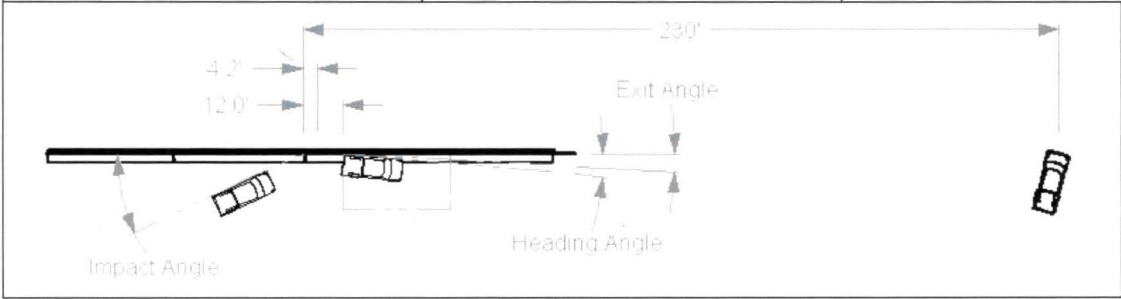

General Information

Test Agency..... Texas A&M Transportation Institute (TTI)
 Test Standard Test No..... MASH Test 4-11
 TTI Test No. 608331-01-2
 Test Date 2018-12-12

Test Article

Type Bridge Rail
 Name..... 2019 MASH 2-Tube Bridge Rail
 Installation Length..... 154 ft
 Material or Key Elements... Two Steel Tubular Rail Elements on Fabricated Steel Posts spaced at 10 ft with 24-inch and 38-inch rail heights and mounted to concrete curb Installed on Reinforced Concrete Bridge Installed on Deck, Damp

Soil Type and Condition..... Deck, Damp

Test Vehicle

Type/Designation..... 2270P
 Make and Model 2012 RAM 1500 Pickup
 Curb..... 4902 lb
 Test Inertial 5019 lb
 Dummy 165 lb
 Gross Static 5184 lb

Impact Conditions

Speed 62.9 mi/h
 Angle 24.9°
 Location/Orientation 4.2 ft upstream of post 9

Impact Severity..... 118 kip-ft

Exit Conditions

Speed 52.9 mi/h
 Exit Trajectory/Heading 8.7°/6.5°

Occupant Risk Values

Longitudinal OIV 16.7 ft/s
 Lateral OIV..... 29.5 ft/s
 Longitudinal Ridedown 8.2 g
 Lateral Ridedown 13.6 g
 THIV 37.6 km/h
 PHD..... 13.6 g
 ASI 2.21

Max. 0.050-s Average

Longitudinal -7.9 g
 Lateral..... 17.0 g
 Vertical..... 3.7 g

Post-Impact Trajectory

Stopping Distance..... 230 ft downstream

Vehicle Stability

Maximum Yaw Angle 33°
 Maximum Pitch Angle 3°
 Maximum Roll Angle 5°
 Vehicle Snagging No
 Vehicle Pocketing No

Test Article Deflections

Dynamic..... 7.1 inches
 Permanent 2.0 inches
 Working Width..... 20.2 inches
 Height of Working Width 38 inches, or Top of post

Vehicle Damage

VDS
 CDC 11LFQ5
 Max. Exterior Deformation..... 11FLEW4
 OCDI..... 11.0 inches
 Max. Occupant Compartment Deformation LF0010000
 Deformation 0.5 inch

Summary of Results for MASH Test 4-11 on 2019 MASH 2-Tube Bridge Rail.

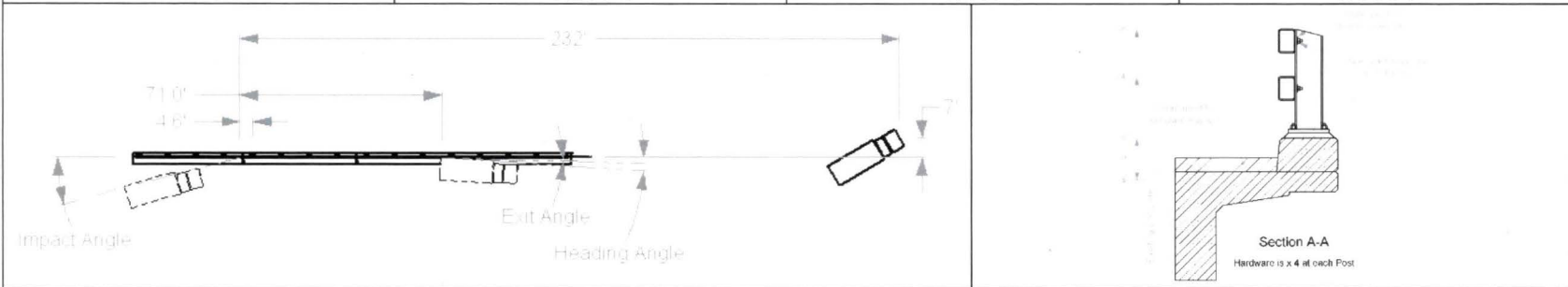

General Information

Test Agency..... Texas A&M Transportation Institute (TTI)
 Test Standard Test No..... MASH Test 4-12
 TTI Test No. 608331-01-1A
 Test Date..... 2018-12-10

Test Article

Type Bridge Rail
 Name 2019 MASH 2-Tube Bridge Rail
 Installation Length..... 154 ft
 Material or Key Elements ... Two Steel Tubular Rail Elements on Fabricated Steel Posts spaced at 10 ft with 24-inch and 38-inch rail heights and mounted to concrete curb
 Installed on Reinforced Concrete Bridge

Soil Type and Condition

Deck, Damp

Test Vehicle

10000S
 Type/Designation..... 2011 International 4300
 Make and Model 14,000 lb
 Curb..... 22,050 lb
 Test Inertial..... No dummy
 Dummy 22,050 lb
 Gross Static

Impact Conditions

Speed 57.4 mi/h
 Angle 15.5°
 Location/Orientation..... 4.6 ft upstream of post 5

Impact Severity.....

173 kip-ft

Exit Conditions

Speed Not obtainable
 Angle Not obtainable

Occupant Risk Values

Longitudinal OIV 6.2 ft/s
 Lateral OIV..... 12.1 ft/s
 Longitudinal Ridedown 3.0 g
 Lateral Ridedown 6.8 g
 THIV 15.4 km/h
 PHD..... 6.9 g
 ASI..... 0.43
 Max. 0.050-s Average
 Longitudinal -1.6 g
 Lateral..... 4.2 g
 Vertical..... -4.1 g

Post-Impact Trajectory

Stopping Distance..... 232 ft downstream
 7 ft twd field side

Vehicle Stability

Maximum Yaw Angle 19°
 Maximum Pitch Angle 9°
 Maximum Roll Angle 19°
 Vehicle Snagging No
 Vehicle Pocketing No

Test Article Deflections

Dynamic..... 3.0 inches
 Permanent 2.0 inches
 Working Width..... 56.7 inches
 Height of Working Width 136.8 inches

Vehicle Damage

VDS NA
 CDC..... 11FREW4
 Max. Exterior Deformation..... 12.0 inches
 OCCDI..... NA
 Max. Occupant Compartment Deformation..... 5.5 inches

Summary of Results for MASH Test 4-12 on 2019 MASH 2-Tube Bridge Rail.

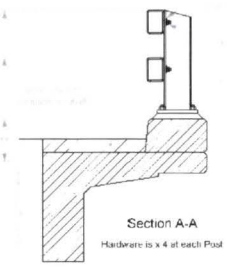
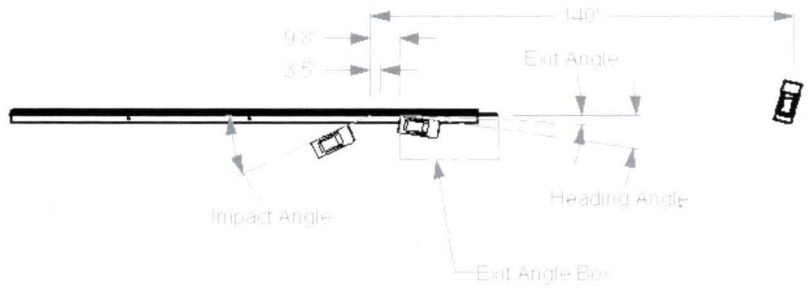

General Information

Test Agency..... Texas A&M Transportation Institute (TTI)
 Test Standard Test No..... MASH Test 4-10
 TTI Test No. 608331-01-3
 Test Date 2018-12-14

Test Article

Type Bridge Rail
 Name 2019 MASH 2-Tube Bridge Rail
 Installation Length..... 154 ft
 Material or Key Elements ... Two Steel Tubular Rail Elements on Fabricated Steel Posts spaced at 10 ft with 24-inch and 38-inch rail heights and mounted to concrete curb Installed on Reinforced Concrete Bridge

Soil Type and Condition

Deck, Damp

Test Vehicle

Type/Designation..... 1100C
 Make and Model 2010 Kia Rio
 Curb..... 2484 lb
 Test Inertial..... 2454 lb
 Dummy 165 lb
 Gross Static..... 2619 lb

Impact Conditions

Speed 62.5 mi/h
 Angle 25.3°
 Location/Orientation 3.5 ft upstream of post 13

Impact Severity.....

58 kip-ft

Exit Conditions

Speed 45.3 mi/h
 Exit Trajectory/Heading 4.8°/6.0°

Occupant Risk Values

Longitudinal OIV 30.2 ft/s
 Lateral OIV..... 30.8 ft/s
 Longitudinal Ridedown 15.3 g
 Lateral Ridedown 6.3 g
 THIV 46.9 km/h
 PHD 16.4 g
 ASI..... 2.65

Max. 0.050-s Average

Longitudinal -17.3 g
 Lateral..... 18.4 g
 Vertical..... -3.3 g

Post-Impact Trajectory

Stopping Distance..... 140 ft downstream
 11 ft twd field side

Vehicle Stability

Maximum Yaw Angle 34°
 Maximum Pitch Angle 5°
 Maximum Roll Angle 5°
 Vehicle Snagging No
 Vehicle Pocketing No

Test Article Deflections

Dynamic..... 2.8 inches
 Permanent 1.0 inch
 Working Width..... 8.5 inches
 Height of Working Width 44.3 inches

Vehicle Damage

VDS 11LFQ5
 CDC 11FLEW4
 Max. Exterior Deformation..... 11.0 inches
 OCDI..... LF0030000
 Max. Occupant Compartment Deformation 4.0 inches

Summary of Results for MASH Test 4-10 on 2019 MASH 2-Tube Bridge Rail.

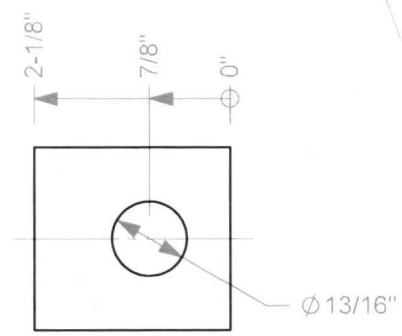
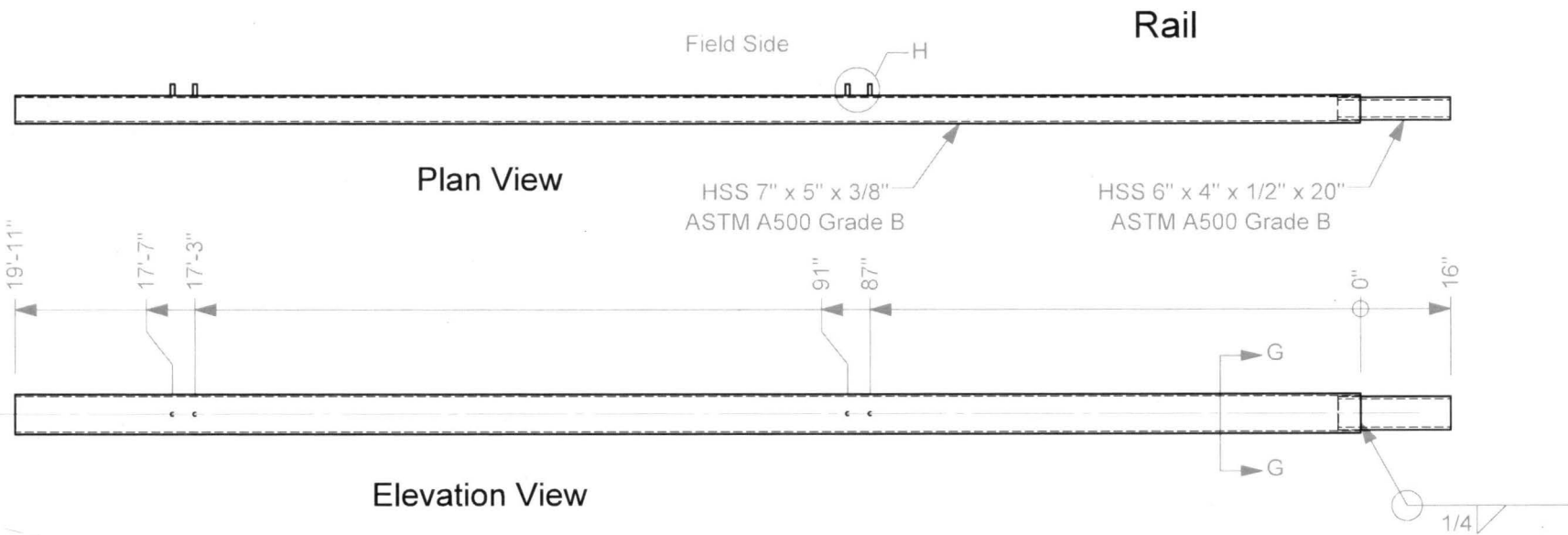
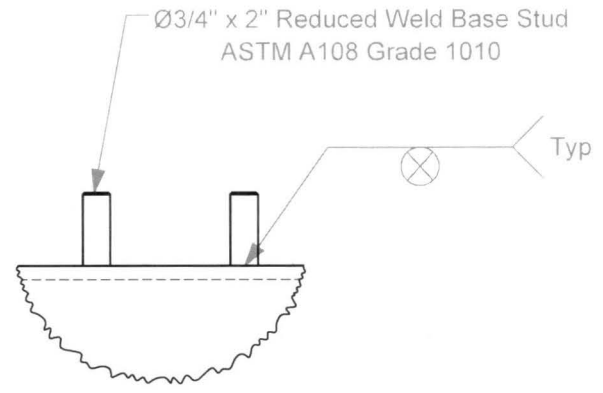
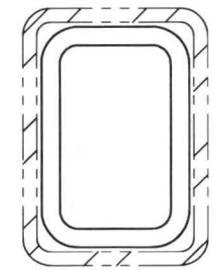

Plate Washer
 Plate, 2" x 1/4" x 2 1/8"
 ASTM A709 Grade 36



Detail H
 Scale 1 : 5



Section G-G
 Scale 1 : 5



Roadside Safety and
 Physical Security Division -
 Proving Ground

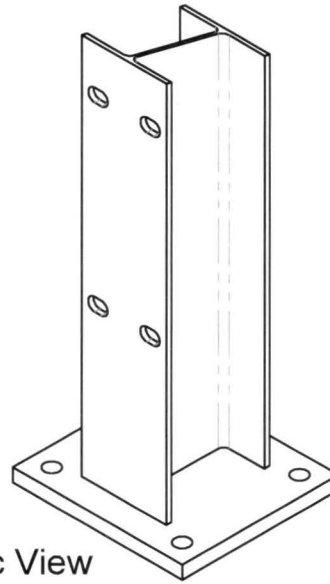
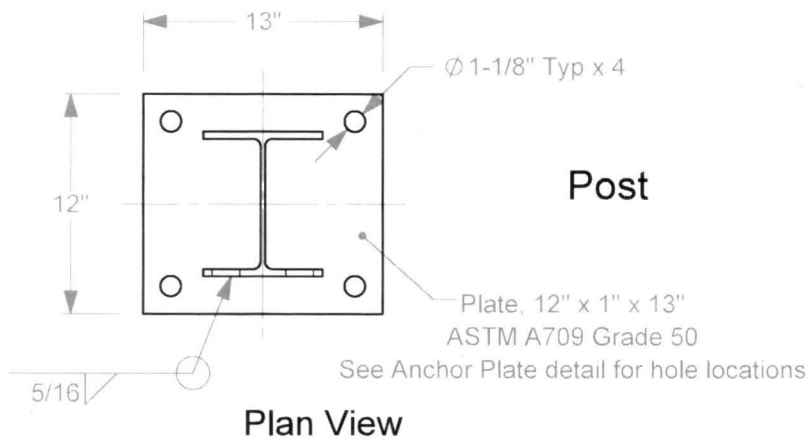

Anchor Plate

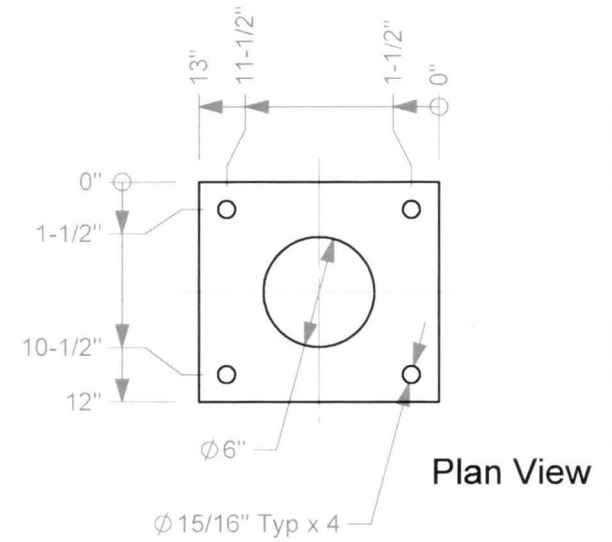
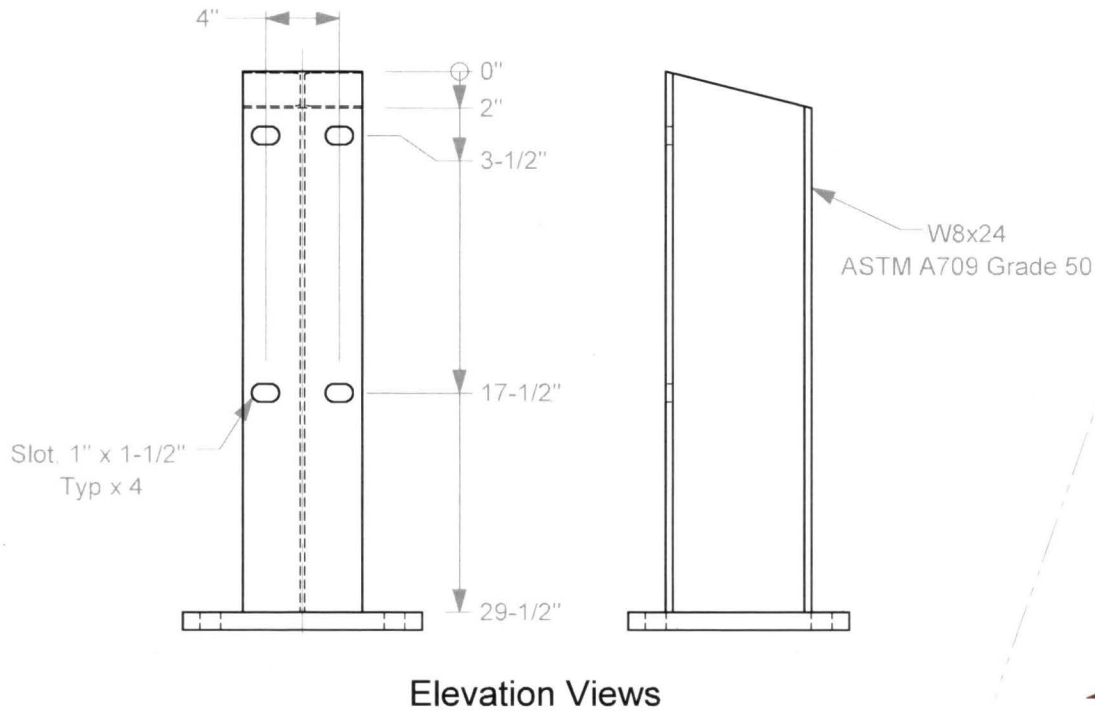
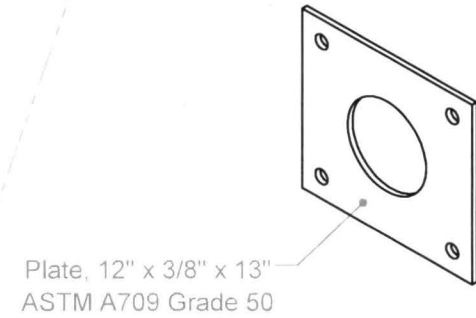

Roadside Safety and
Physical Security Division -
Proving Ground

Project #608331 Alaska Bridge Rail

2018-05-14

Drawn by GES Scale 1:10 Sheet 6 of 7 Post and Anchor Plate

Details, Plan

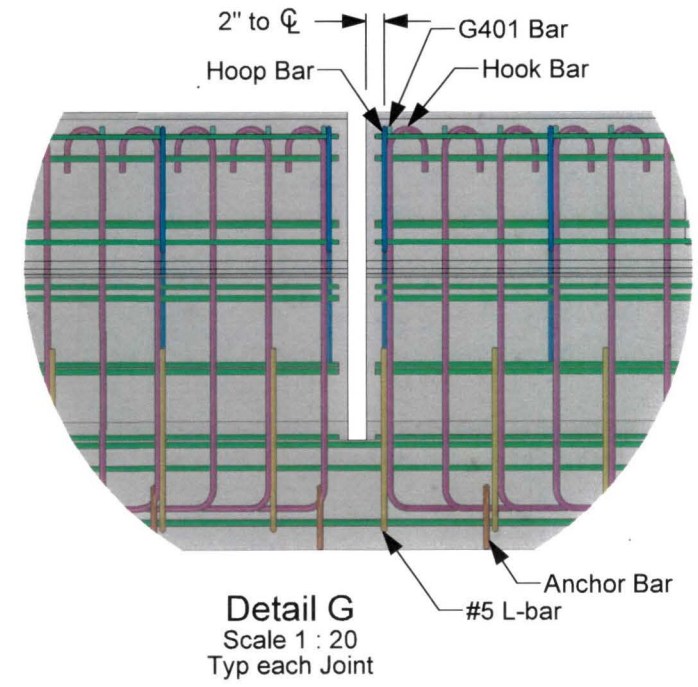
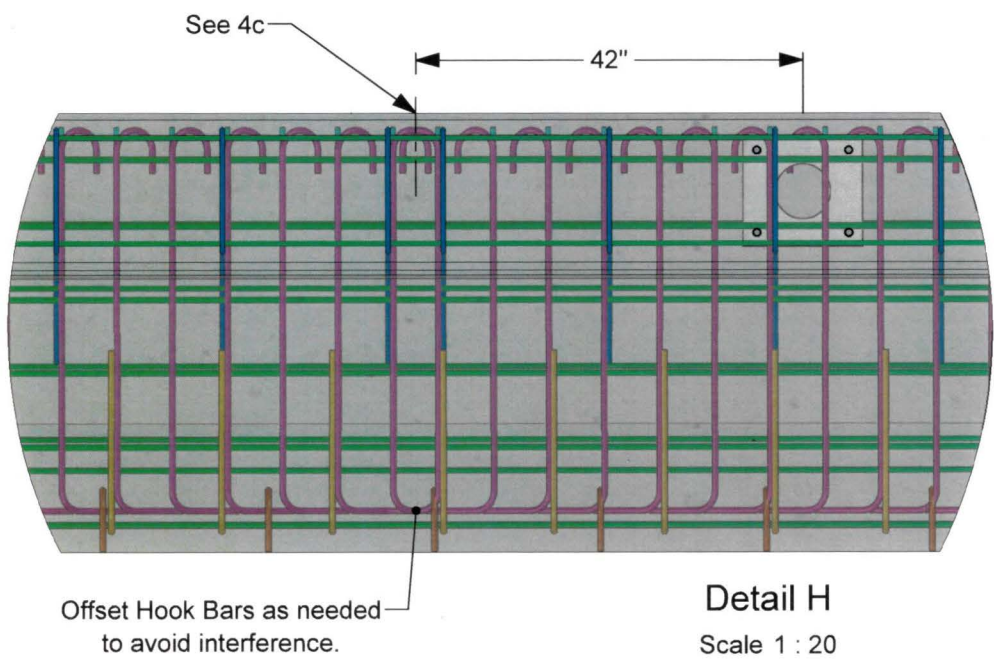
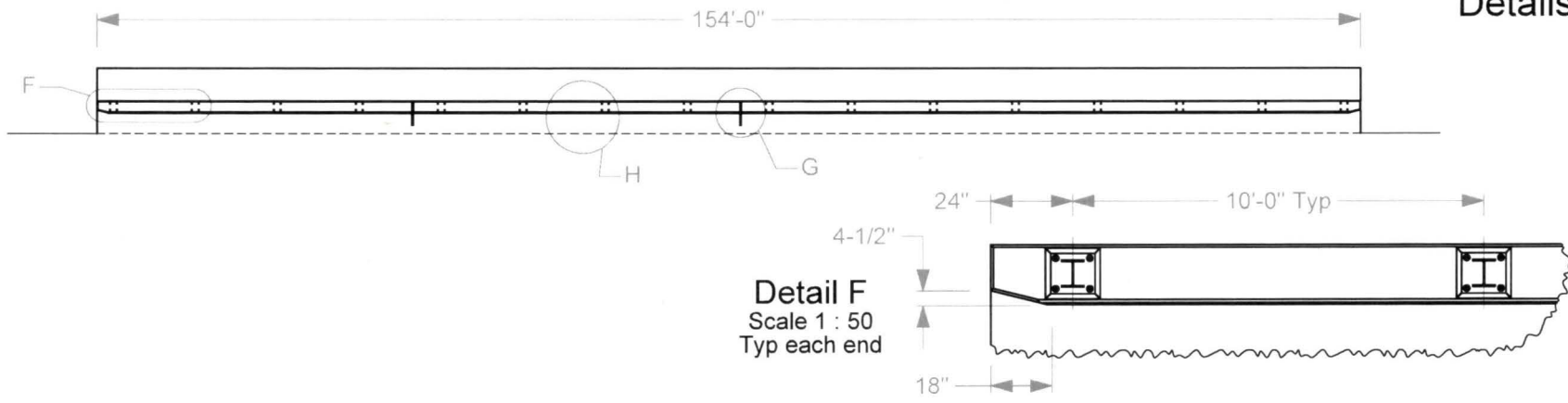

- 4a.** Concrete Strength is 5000psi for the Wall and Deck, 3000 psi for the Working Slab, and 4000 psi for the Curb.
- 4b.** Chamfer Field Side edges of Deck, and field side and top edges at end of Curb 3/4" each way as shown.
- 4c.** Rebar placement shown in Detail View at joint is typical each joint. Adjust spacing and Hook Bar direction as needed at location shown.



Roadside Safety and Physical Security Division - Proving Ground

Project #608331 Alaska Bridge Rail 2018-05-14
 Drawn by GES Scale 1:250 Sheet 4 of 7 Details, Plan

T:\1-ProjectFiles\608331-Alaska - Williams\Drafting, 608331 1-31608331 Drawing

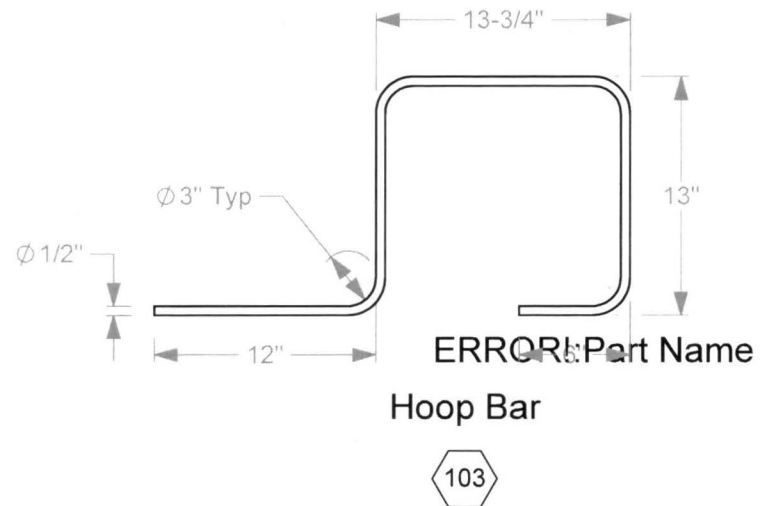
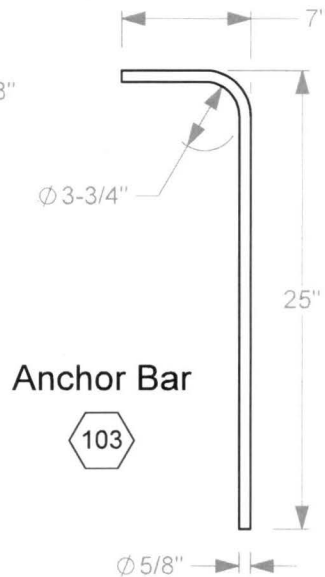
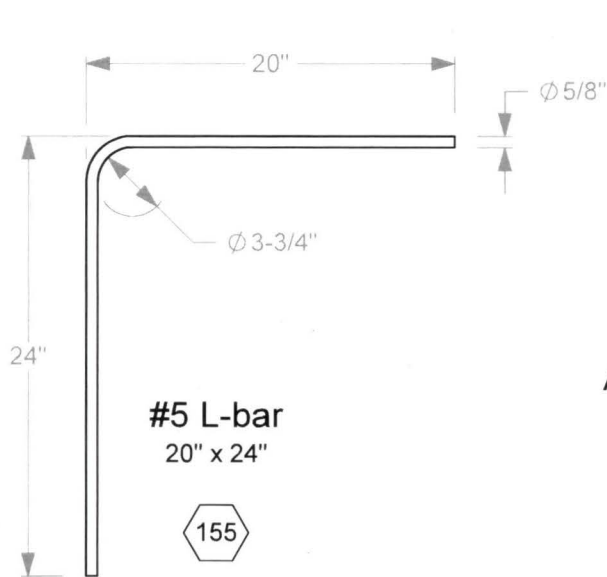
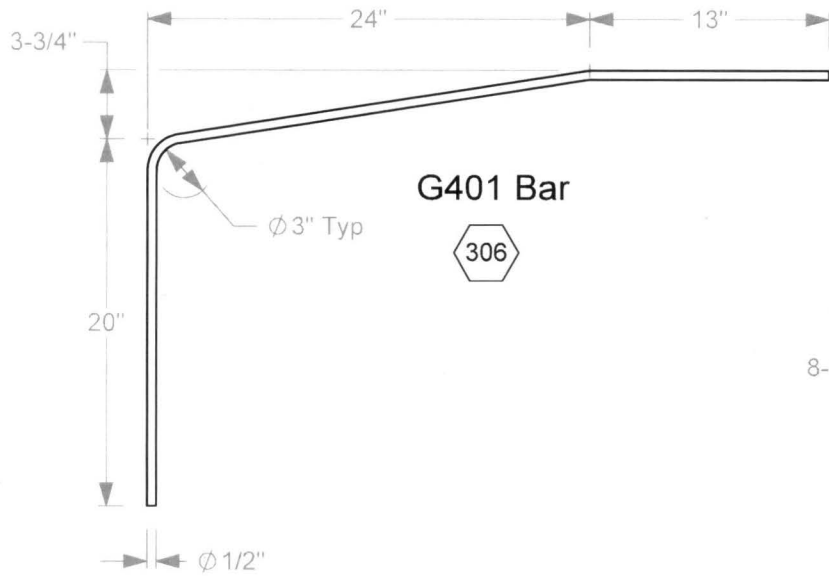

5a. All bent bars, and all longitudinal bars in the Curb, Deck and Wall shall be epoxy coated. All bars are grade 60..



Roadside Safety and
Physical Security Division -
Proving Ground

Project #608331 Alaska Bridge Rail

2018-05-14

Drawn by GES Scale 1:10

Sheet 5 of 7 Rebar

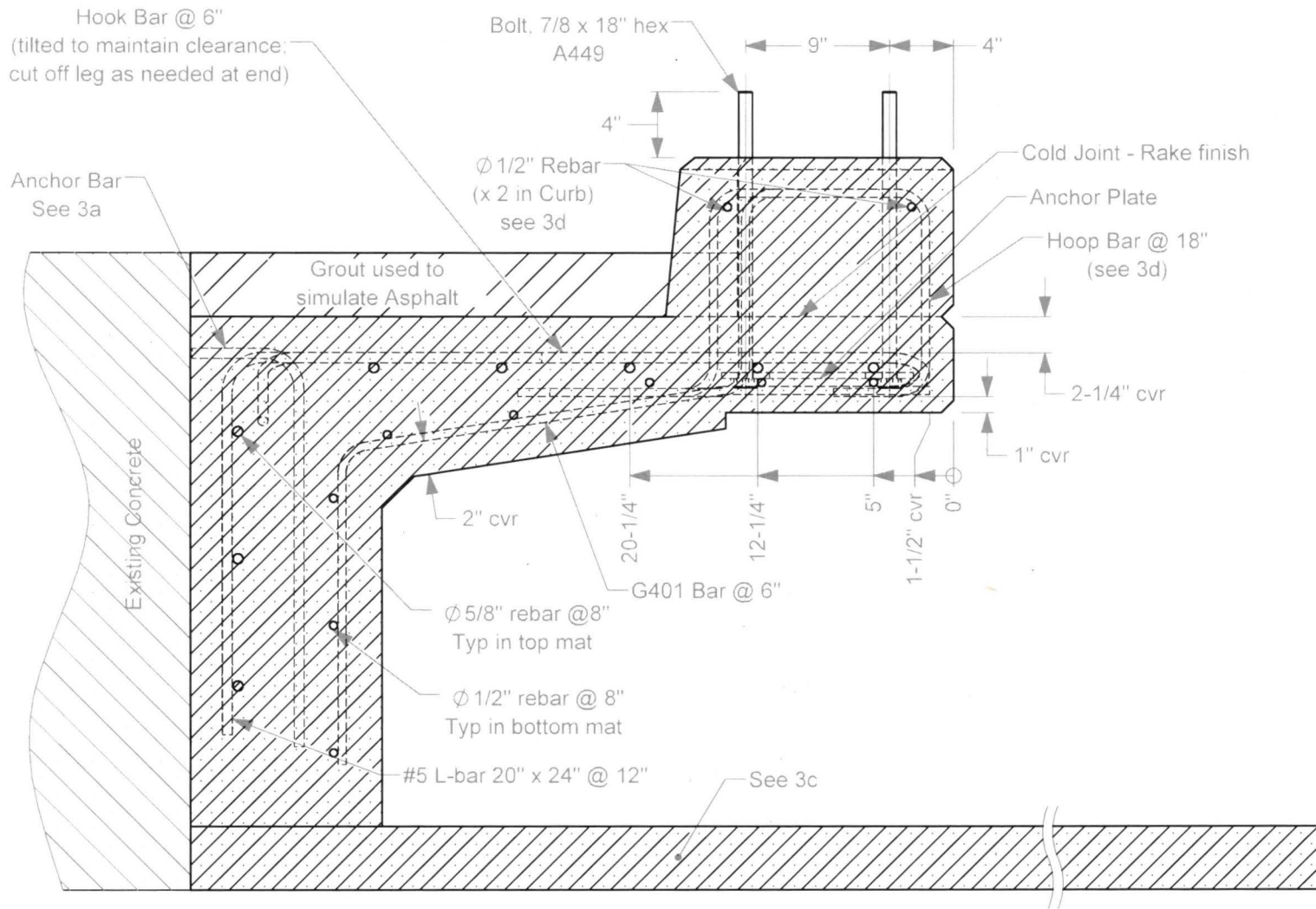

Section E-E

Scale 1 : 10

- 3a.** Place the Anchor Bars @ maximum 18" spacing and secure to existing rebar protruding from the runway with minimum 3" weld. (Existing rebar not shown here.)
- 3b.** Minimum rebar lap is 24" for #4 bars and 30" for #5 bars.
- 3c.** Place one mat of Ø1/2" (#4) bars in Working Slab @ 12" each way with ≈1-1/2" cover at top. These bars are not shown here.
- 3d.** Field bend traffic side longitudinal bar and turn Hoop Bars at ends of Curb to maintain cover.
- 3e.** The Anchor Bars will be bare steel, and the bars in the Working Slab may be bare steel. All other bars shall be epoxy coated, and all bars are grade 60.



Roadside Safety and
Physical Security Division -
Proving Ground

Project #608331 Alaska Bridge Rail

2018-05-14

Drawn by GES Scale 1:10

Sheet 3 of 7 Rebar Details

Test Installation

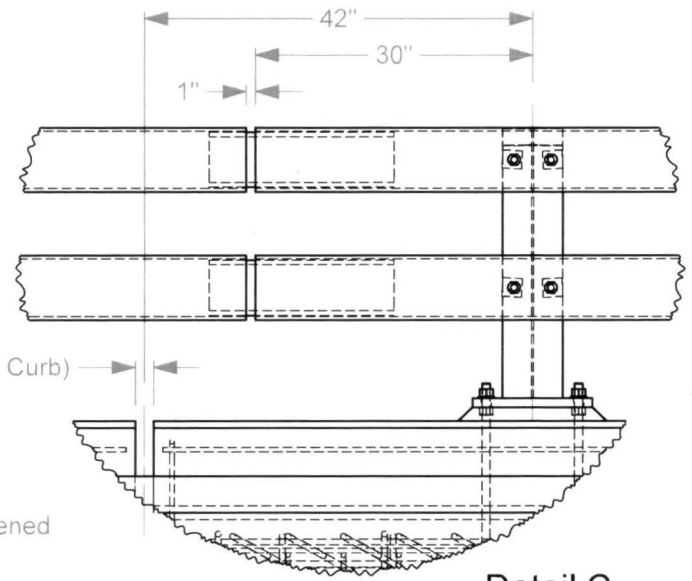
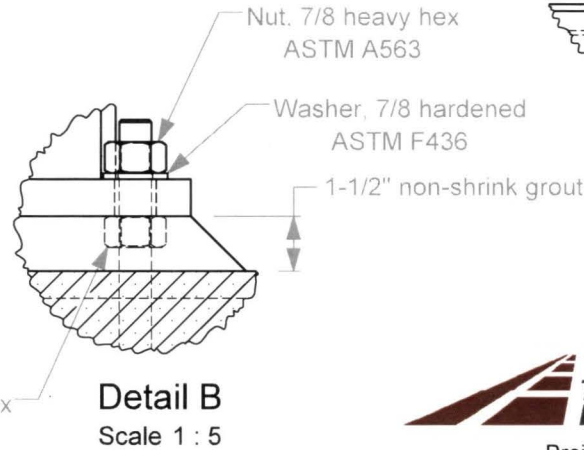
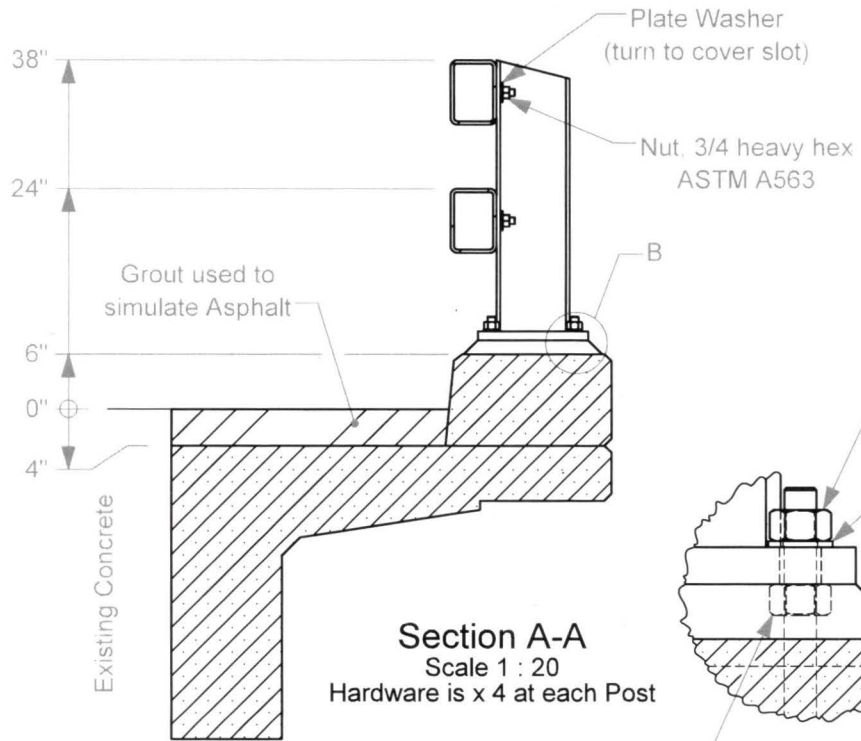
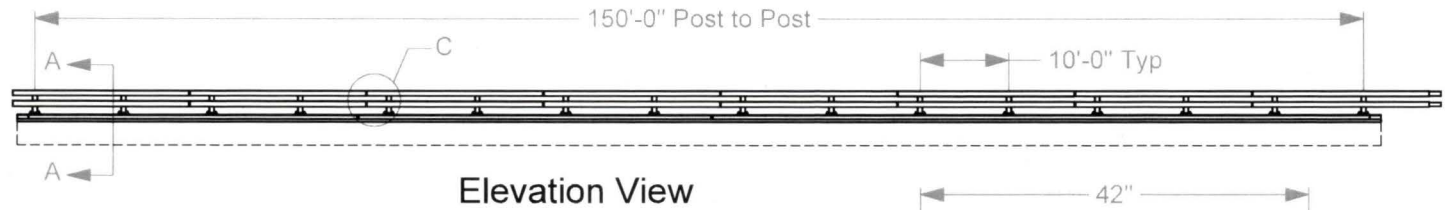
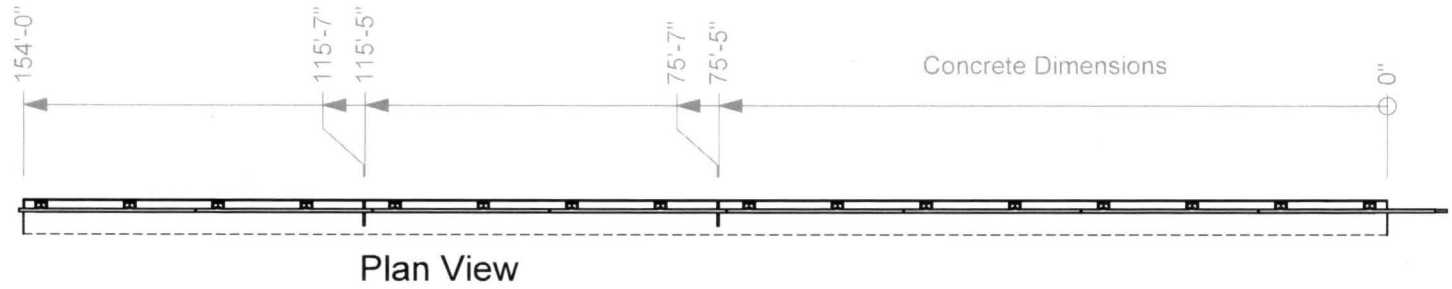

Detail C
Scale 1 : 20
Typ each Rail joint (7)
and Deck and Curb joint (2)



Roadside Safety and
Physical Security Division -
Proving Ground

Project #608331 Alaska Bridge Rail

2018-05-14

Drawn by GES Scale 1:250

Sheet 1 of 7 Test Installation

Details, Elevation

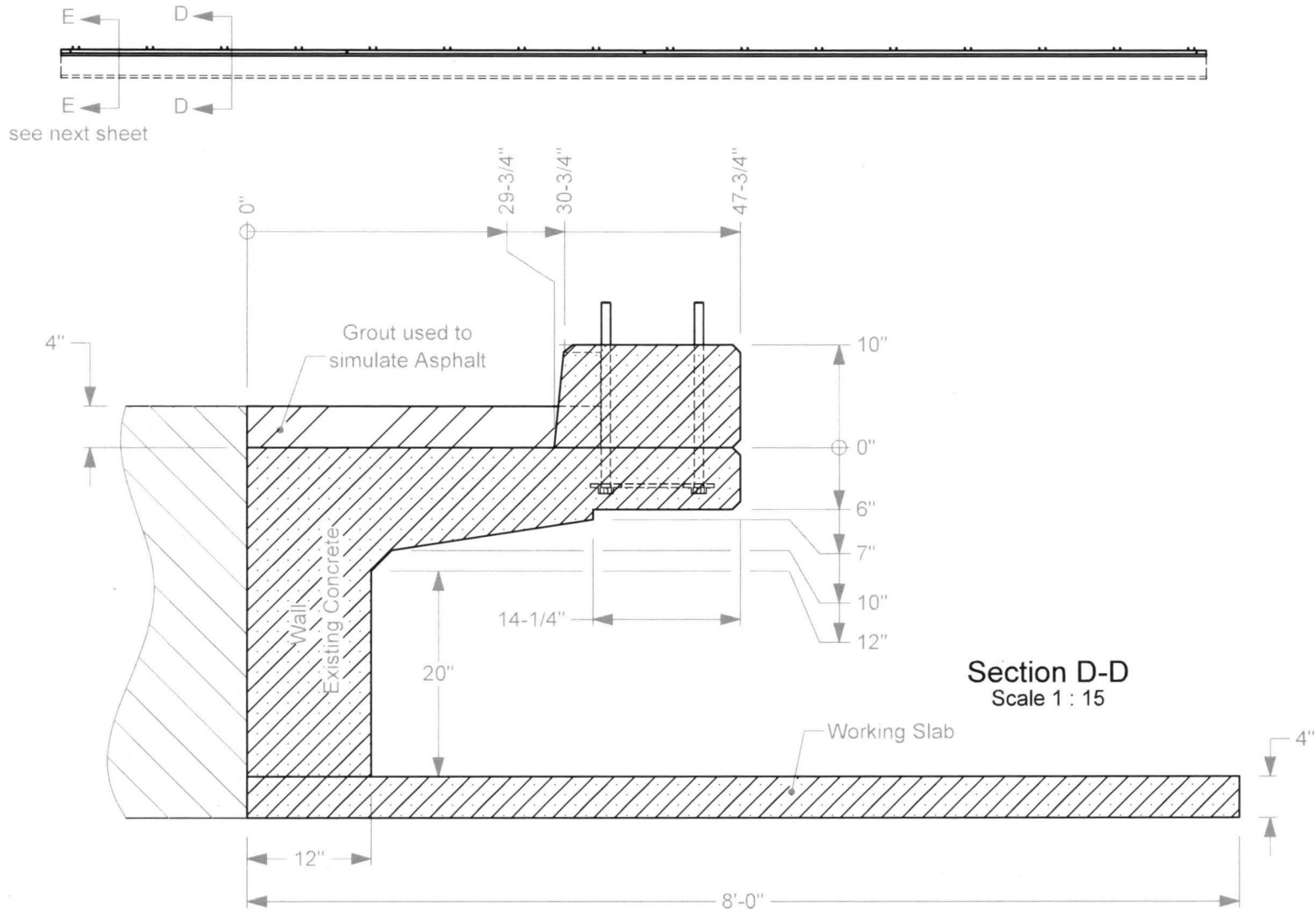

2a. Concrete Strength is 5000psi for the Wall and Deck, 3000 psi for the Working Slab, and 4000 psi for the Curb.

2b. Chamfer Field Side edges of Deck, and field side and top edges of end of Curb 3/4" each way as shown.



Roadside Safety and
Physical Security Division -
Proving Ground

Project #608331 Alaska Bridge Rail

2018-05-14

Drawn by GES Scale 1:250

Sheet 2 of 7 Details, Elevation

 Texas A&M Transportation Institute Proving Ground 3100 SH 47, Bldg 7091 Bryan, TX 77807 Texas A&M University College Station, TX 77843 Phone 979-845-6375	5.8 Test Item Preparation/ Installation Specifications	Doc. No.	Revision Date:
		QPF 5.8	2012-09-17
Quality Policy Form	Revised by: G. E. Schroeder Approved by: R. A. Zimmer	Revision: 7	Page: 1 of 1

TTI Project No./Name: 608331	Test Item Identification: Alaska Bridge Deck
Principal Investigator (PI): William Williams	Initial Drawing Date: 2018-03-01
Sponsor: Alaska DOT	Phone:
Name of Sponsor Representative: Elmer Marx	e-mail address: elmer.marx@alaska.gov
Sponsor Approval Signature: By email	Approval Date: 2018-02-28
PI Approval:	Approval Date:

The section below shall be used to briefly summarize revisions and dates revisions made.
TTI QPF 5.8 shall be completed for each test item.

Revisions:	
Date of Revision:	Brief Description:
2018-03-07	Changed direction of ordinate dimension: sheet 2 Added quantities: sheet 4
2018-03-23	Modified Hook Bar
2018-06-12	Added chamfer and one dimension on sheet 3
2019-02-15	Changed asphalt to grout, sheet 1
2019-04-01	Edited asphalt notes; sheets 1, 2, & 3
Printed Name of Sponsor Representative, if other than name listed above:	
Alternate Sponsor Representative Signature:	Date: